

Installation Guide

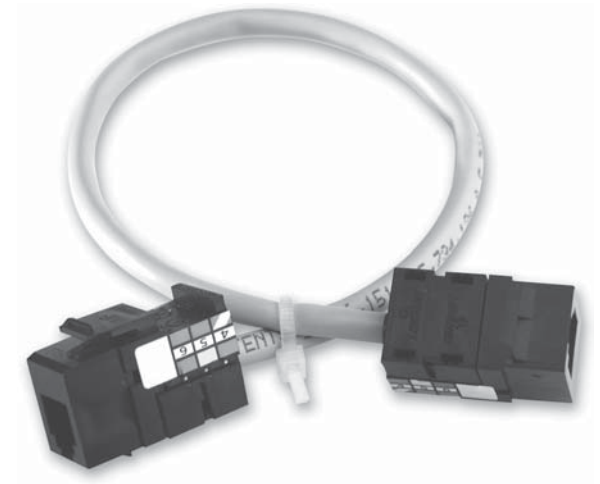

RJ-45 to RJ-11 Conversion Kit Installation Instructions for HSA 400 Series and HSA 800 Series Enclosures

68-699-02 **Rev. B**
Printed in the USA
02 03



Extron Electronics, USA
1230 South Lewis Street
Anaheim, CA 92805
USA
714.491.1500
Fax 714.491.1517

Extron Electronics, Europe
Beeldschermweg 6C
3821 AH Amersfoort
The Netherlands
+31.33.453.4040
Fax +31.33.453.4050

Extron Electronics, Asia
135 Joo Seng Road, #04-01
PM Industrial Building
Singapore 368363
+65.6383.4400
Fax +65.6383.4664

Extron Electronics, Japan
Daisan DMJ Building 6F
3-9-1 Kudan Minami
Chiyoda-ku, Tokyo 102-0074 Japan
+81.3.3511.7655
Fax +81.3.3511.7656

Precautions

Safety Instructions • English



This symbol is intended to alert the user of important operating and maintenance (servicing) instructions in the literature provided with the equipment.



This symbol is intended to alert the user of the presence of uninsulated dangerous voltage within the product's enclosure that may present a risk of electric shock.

Caution

Read Instructions • Read and understand all safety and operating instructions before using the equipment.

Retain Instructions • The safety instructions should be kept for future reference.

Follow Warnings • Follow all warnings and instructions marked on the equipment or in the user information.

Avoid Attachments • Do not use tools or attachments that are not recommended by the equipment manufacturer because they may be hazardous.

Consignes de Sécurité • Français



Ce symbole sert à avertir l'utilisateur que la documentation fournie avec le matériel contient des instructions importantes concernant l'exploitation et la maintenance (réparation).



Ce symbole sert à avertir l'utilisateur de la présence dans le boîtier de l'appareil de tensions dangereuses non isolées posant des risques d'électrocution.

Attention

Lire les instructions • Prendre connaissance de toutes les consignes de sécurité et d'exploitation avant d'utiliser le matériel.

Conservier les instructions • Ranger les consignes de sécurité afin de pouvoir les consulter à l'avenir.

Respecter les avertissements • Observer tous les avertissements et consignes marqués sur le matériel ou présentés dans la documentation utilisateur.

Eviter les pièces de fixation • Ne pas utiliser de pièces de fixation ni d'outils non recommandés par le fabricant du matériel car cela risquerait de poser certains dangers.

Sicherheitsanleitungen • Deutsch



Dieses Symbol soll dem Benutzer in der im Lieferumfang enthaltenen Dokumentation besonders wichtige Hinweise zur Bedienung und Wartung (Instandhaltung) geben.



Dieses Symbol soll den Benutzer darauf aufmerksam machen, daß im Inneren des Gehäuses dieses Produktes gefährliche Spannungen, die nicht isoliert sind und die einen elektrischen Schock verursachen können, herrschen.

Achtung

Lesen der Anleitungen • Bevor Sie das Gerät zum ersten Mal verwenden, sollten Sie alle Sicherheits- und Bedienungsanleitungen genau durchlesen und verstehen.

Aufbewahren der Anleitungen • Die Hinweise zur elektrischen Sicherheit des Produktes sollten Sie aufbewahren, damit Sie im Bedarfsfall darauf zurückgreifen können.

Befolgen der Warnhinweise • Befolgen Sie alle Warnhinweise und Anleitungen auf dem Gerät oder in der Benutzerdokumentation.

Keine Zusatzgeräte • Verwenden Sie keine Werkzeuge oder Zusatzgeräte, die nicht ausdrücklich vom Hersteller empfohlen wurden, da diese eine Gefahrenquelle darstellen können.

Instrucciones de seguridad • Español



Este símbolo se utiliza para advertir al usuario sobre instrucciones importantes de operación y mantenimiento (o cambio de partes) que se desean destacar en el contenido de la documentación suministrada con los equipos.



Este símbolo se utiliza para advertir al usuario sobre la presencia de elementos con voltaje peligroso sin protección aislante, que puedan encontrarse dentro de la caja o alojamiento del producto, y que puedan representar riesgo de electrocución.

Precaución

Leer las instrucciones • Leer y analizar todas las instrucciones de operación y seguridad, antes de usar el equipo.

Conservar las instrucciones • Conservar las instrucciones de seguridad para futura consulta.

Obedecer las advertencias • Todas las advertencias e instrucciones marcadas en el equipo o en la documentación del usuario, deben ser obedecidas.

Evitar el uso de accesorios • No usar herramientas o accesorios que no sean específicamente recomendados por el fabricante, ya que podrían implicar riesgos.

Warning

Power sources • This equipment should be operated only from the power source indicated on the product. This equipment is intended to be used with a main power system with a grounded (neutral) conductor. The third (grounding) pin is a safety feature, do not attempt to bypass or disable it.

Power disconnection • To remove power from the equipment safely, remove all power cords from the rear of the equipment, or the desktop power module (if detachable), or from the power source receptacle (wall plug).

Power cord protection • Power cords should be routed so that they are not likely to be stepped on or pinched by items placed upon or against them.

Servicing • Refer all servicing to qualified service personnel. There are no user-serviceable parts inside. To prevent the risk of shock, do not attempt to service this equipment yourself because opening or removing covers may expose you to dangerous voltage or other hazards.

Slots and openings • If the equipment has slots or holes in the enclosure, these are provided to prevent overheating of sensitive components inside. These openings must never be blocked by other objects.

Lithium battery • There is a danger of explosion if battery is incorrectly replaced. Replace it only with the same or equivalent type recommended by the manufacturer. Dispose of used batteries according to the manufacturer's instructions.

Avertissement

Alimentations • Ne faire fonctionner ce matériel qu'avec la source d'alimentation indiquée sur l'appareil. Ce matériel doit être utilisé avec une alimentation principale comportant un fil de terre (neutre). Le troisième contact (de mise à la terre) constitue un dispositif de sécurité: n'essayez pas de le contourner ni de la désactiver.

Déconnexion de l'alimentation • Pour mettre le matériel hors tension sans danger, déconnectez tous les cordons d'alimentation de l'arrière de l'appareil ou du module d'alimentation de bureau (s'il est amovible) ou encore de la prise secteur.

Protection du cordon d'alimentation • Acheminer les cordons d'alimentation de manière à ce que personne ne risque de marcher dessus et à ce qu'ils ne soient pas écrasés ou pincés par des objets.

Réparation-maintenance • Faire exécuter toutes les interventions de réparation-maintenance par un technicien qualifié. Aucun des éléments internes ne peut être réparé par l'utilisateur. Afin d'éviter tout danger d'électrocution, l'utilisateur ne doit pas essayer de procéder lui-même à ces opérations car l'ouverture ou le retrait des couvercles risquent de l'exposer à de hautes tensions et autres dangers.

Fentes et orifices • Si le boîtier de l'appareil comporte des fentes ou des orifices, ceux-ci servent à empêcher les composants internes sensibles de surchauffer. Ces ouvertures ne doivent jamais être bloquées par des objets.

Lithium Batterie • Il a danger d'explosion s'il y a remplacement incorrect de la batterie. Remplacer uniquement avec une batterie du même type ou d'un type équivalent recommandé par le constructeur. Mettre au reut les batteries usagées conformément aux instructions du fabricant.

Vorsicht

Stromquellen • Dieses Gerät sollte nur über die auf dem Produkt angegebene Stromquelle betrieben werden. Dieses Gerät wurde für eine Verwendung mit einer Hauptstromleitung mit einem geerdeten (neutralen) Leiter konzipiert. Der dritte Kontakt ist für einen Erdschluss, und stellt eine Sicherheitsfunktion dar. Diese sollte nicht umgangen oder außer Betrieb gesetzt werden.

Stromunterbrechung • Um das Gerät auf sichere Weise vom Netz zu trennen, sollten Sie alle Netzkabel aus der Rückseite des Gerätes, aus der externen Stromversorgung (falls dies möglich ist) oder aus der Wandsteckdose ziehen.

Schutz des Netzkabels • Netzkabel sollten stets so verlegt werden, daß sie nicht im Weg liegen und niemand darauf treten kann oder Objekte darauf- oder unmittelbar dagegestellt werden können.

Wartung • Alle Wartungsmaßnahmen sollten nur von qualifiziertem Servicepersonal durchgeführt werden. Die internen Komponenten des Gerätes sind wartungsfrei. Zur Vermeidung eines elektrischen Schocks versuchen Sie in keinem Fall, dieses Gerät selbst öffnen, da beim Entfernen der Abdeckungen die Gefahr eines elektrischen Schlags und/oder andere Gefahren bestehen.

Schlitze und Öffnungen • Wenn das Gerät Schlitze oder Löcher im Gehäuse aufweist, dienen diese zur Vermeidung einer Überhitzung der empfindlichen Teile im Inneren. Diese Öffnungen dürfen niemals von anderen Objekten blockiert werden.

Litium-Batterie • Explosionsgefahr, falls die Batterie nicht richtig ersetzt wird. Ersetzen Sie verbrauchte Batterien nur durch den gleichen oder einen vergleichbaren Batterietyp, der auch vom Hersteller empfohlen wird. Entsorgen Sie verbrauchte Batterien bitte gemäß den Herstelleranweisungen.

Advertencia

Alimentación eléctrica • Este equipo debe conectarse únicamente a la fuente/tipo de alimentación eléctrica indicada en el mismo. La alimentación eléctrica de este equipo debe provenir de un sistema de distribución general con conductor neutro a tierra. La tercera pata (puesta a tierra) es una medida de seguridad, no puede ser eliminada.

Desconexión de alimentación eléctrica • Para desconectar con seguridad la acometida de alimentación eléctrica al equipo, desenchufar todos los cables de alimentación en el panel trasero del equipo, o desenchufar el módulo de alimentación (si fuera independiente), o desenchufar el cable del receptáculo de la pared.

Protección del cables de alimentación • Los cables de alimentación eléctrica se deben instalar en lugares donde no sean pisados ni apretados por objetos que se puedan apoyar sobre ellos.

Reparaciones/mantenimiento • Solicitar siempre los servicios técnicos de personal calificado. En el interior no hay partes a las que el usuario deba acceder. Para evitar riesgo de electrocución, no intentar personalmente la reparación/mantenimiento de este equipo, ya que al abrir o extraer las tapas puede quedar expuesto a voltajes peligrosos u otros riesgos.

Ranuras y aberturas • Si el equipo posee ranuras o orificios en su caja/alojamiento, es para evitar el sobrecalentamiento de componentes internos sensibles. Estas aberturas nunca se deben obstruir con otros objetos.

Batería de litio • Existe riesgo de explosión si esta batería se coloca en la posición incorrecta. Cambiar esta batería únicamente con el mismo tipo (o su equivalente) recomendado por el fabricante. Desachar las baterías usadas siguiendo las instrucciones del fabricante.

Extron's Warranty

Extron Electronics warrants this product against defects in materials and workmanship for a period of three years from the date of purchase. In the event of malfunction during the warranty period attributable directly to faulty workmanship and/or materials, Extron Electronics will, at its option, repair or replace said products or components, to whatever extent it shall deem necessary to restore said product to proper operating condition, provided that it is returned within the warranty period, with proof of purchase and description of malfunction to:

USA, Canada, South America, and Central America:

Extron Electronics
1230 South Lewis Street
Anaheim, CA 92805, USA

Asia:

Extron Electronics, Asia
135 Joo Seng Road, #04-01
PM Industrial Bldg.
Singapore 368363

Europe, Africa, and the Middle East:

Extron Electronics, Europe
Beeldschermweg 6C
3821 AH Amersfoort
The Netherlands

Japan:

Extron Electronics, Japan
Daisan DMJ Bldg, 6F,
3-9-1 Kudan Minami
Chiyoda-ku, Tokyo 102-0074
Japan

This Limited Warranty does not apply if the fault has been caused by misuse, improper handling care, electrical or mechanical abuse, abnormal operating conditions or non-Extron authorized modification to the product.

If it has been determined that the product is defective, please call Extron and ask for an Applications Engineer at (714) 491-1500 (USA), 31.33.453.4040 (Europe), 65.6383.4400 (Asia), or 81.3.3511.7655 (Japan) to receive an RA# (Return Authorization number). This will begin the repair process as quickly as possible.

Units must be returned insured, with shipping charges prepaid. If not insured, you assume the risk of loss or damage during shipment. Returned units must include the serial number and a description of the problem, as well as the name of the person to contact in case there are any questions.

Extron Electronics makes no further warranties either expressed or implied with respect to the product and its quality, performance, merchantability, or fitness for any particular use. In no event will Extron Electronics be liable for direct, indirect, or consequential damages resulting from any defect in this product even if Extron Electronics has been advised of such damage.

Please note that laws vary from state to state and country to country, and that some provisions of this warranty may not apply to you.

Table of Contents

Chapter 1 • HSA 400, 402 Installation	1-1
Introduction	1-2
Removing the HSA from the Table	1-4
Removing the Front Panel Connector	1-6
Replacing the Lower Enclosure Connector	1-7
Replacing the Front Panel Connector and Reassembling the HSA	1-9
Routing the AAP Cables	1-10
Chapter 2 • HSA 800, 802, 822 Installation	2-1
Introduction	2-2
Removing the HSA from the Table	2-3
Replacing the Connectors	2-5
Reassembling the HSA	2-6
Routing the AAP Cables	2-8

All trademarks mentioned in this manual are the properties of their respective owners.

68-699-02 **Rev. B**
Printed in the USA
02 03



This page intentionally left blank

Chapter One

HSA 400, 402 Installation

Introduction

Removing the HSA from the Table

Removing the Front Panel Connector

Replacing the Lower Enclosure Connector

Replacing the Front Panel Connector and Reassembling the HSA

Routing the AAP Cables

Introduction

The Extron HSA 400 and HSA 402 ship with Category (CAT) 6 cables terminated with RJ-45 connectors between the front panel and lower enclosure bezel plug-ins. Some users prefer a telephone (RJ-11) connector. This conversion kit consists of a length of telephone cable terminated with RJ-11 connectors to replace one of the CAT 6/RJ-45 cables.

Figure 1-1 shows the location of the bezel plug-ins on the underside and front panel of the HSA 400. Figure 1-2 shows the location of the bezel plug-ins on the underside and front panel of the HSA 402. When replacing the CAT 6 cable, match the front panel connection (A) with the underside connector (A), match (B) with (B), and so forth.

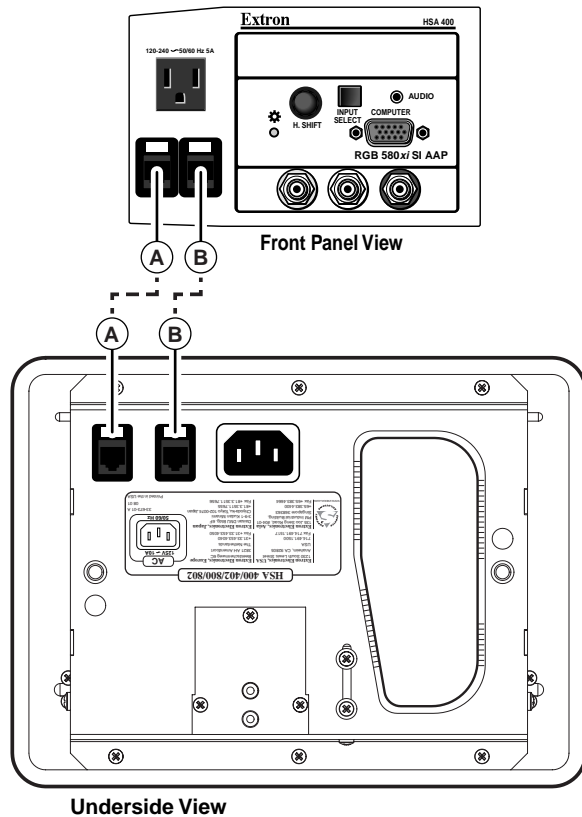

Figure 1-1 — HSA 400 underside and front panel bezel plug-ins

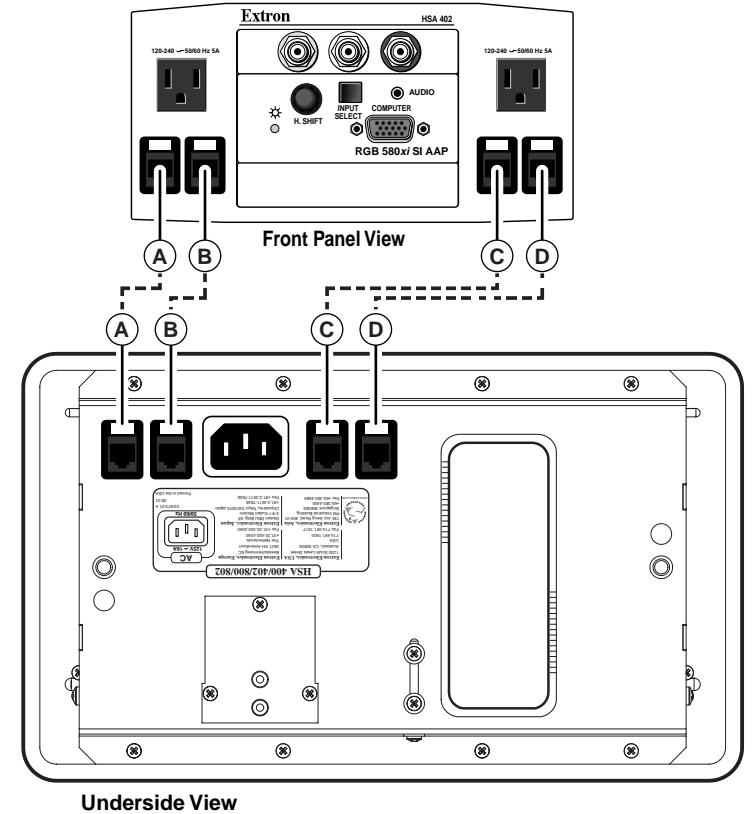

Figure 1-2 — HSA 402 underside and front panel bezel plug-ins

Removing the HSA from the Table

WARNING Ensure that AC power is disconnected before servicing the HSA unit.

1. On the underside of the clamshell and in the enclosure, cut the tie wraps that route the AAP cables out of the way.
2. Disconnect the IEC power cord and the RJ-45 connectors from the underside of the surface mount enclosure.
3. Disconnect any cables connected to the existing AAPs at the ends of the cables away from the HSA.

WARNING The edges of the top panel are sharp. Exercise care when the HSA is removed from the table to prevent personal injury.

CAUTION The edges of the top panel are bevelled to an ultra-fine thickness of less than 0.04 (4/100)" (approximately 1 mm). These edges are soft and can be easily nicked or bent. Exercise caution when handling and mounting the enclosure. Mishandling can damage the appearance of the enclosure.

NOTE The surfaces of the HSA enclosure have screws and other protrusions that could damage fine furniture. Do not rest the enclosure on unprotected furniture.

4. On the underside of the table, remove the two bolts that secure the clamshell to the HSA (figure 1-3). Lift the enclosure out of the table. Ensure that the cables connected to the AAPs do not snag or pull on any protrusions.

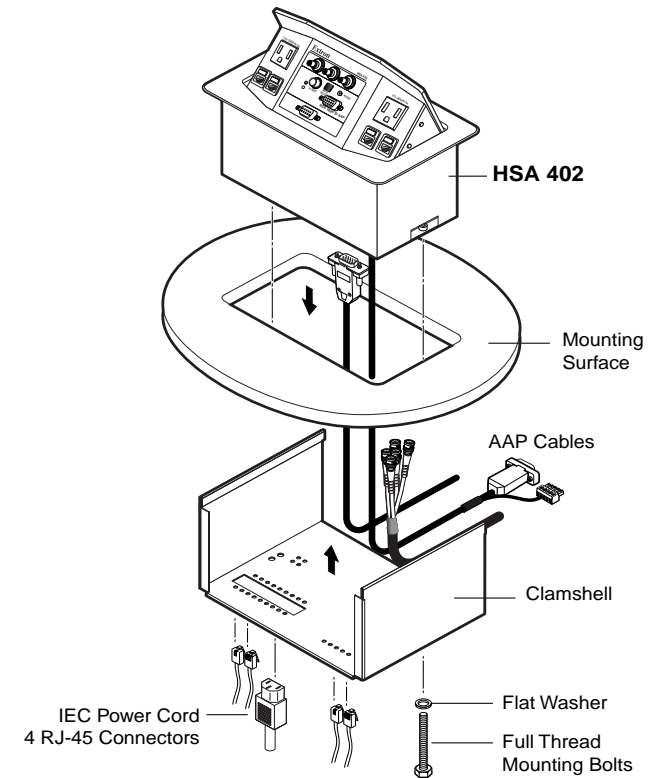

Figure 1-3 — Removing the HSA 402 from the table

Removing the Front Panel Connector

1. Through the access hole in the rear of the enclosure, cut the tie wraps that bundle the power and CAT 6 cables.
2. Through the access hole in the rear of the enclosure, disconnect the 3-prong cable connector on the interior AC cable (figure 1-4).



Figure 1-4 — Disconnecting the interior AC cable

3. Open the top panel and remove and retain the four Allen screws on the right and left sides of the front panel (figure 1-5). Lift the front panel away from the enclosure as far as the connected cables allow.

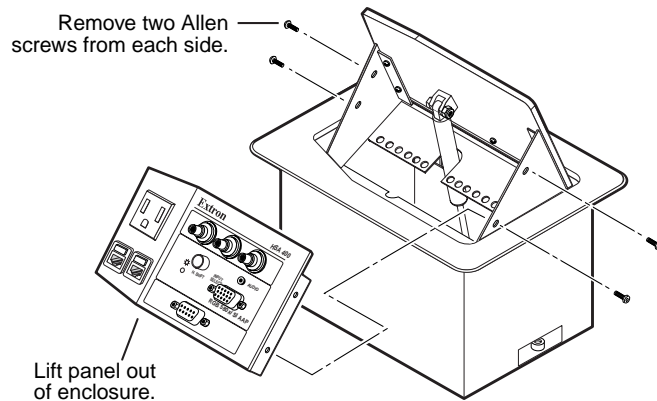
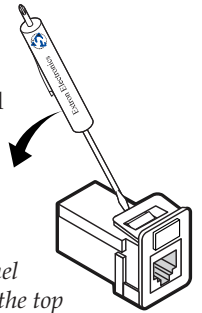

Figure 1-5 — Removing the front panel

4. With a tweezers, push down on and gently twist on the front of each RJ-45 connector detent to disconnect the connector from the rear of the front panel bezel plug-in.
5. Remove the front panel from the enclosure. Leave the top panel open for the time being.



NOTE Ensure that the edges of the front panel do not scratch the finished surface of the top panel flange when removing the panel.

Replacing the Lower Enclosure Connector

1. Identify the RJ-45 connector to be replaced, then **simultaneously**:
 - a. With a tweezers in one hand, reach through the small access hole in the front of the enclosure (figure 1-6) and gently pry outward on the front of the RJ-45 connector detent on the bezel plug-in,
 - b. While you reach your other hand through the access hole in the rear of the enclosure and tilt the connector back.

This disconnects the connector from the interior of the lower enclosure without damaging the bezel plug-in.



Figure 1-6 — Releasing the bezel plug-in detent

- Note how the disconnected CAT 6 cable is routed inside the HSA and then gently pull the cable free.
- Route the conversion kit telephone cable in the same fashion as the removed CAT 6 cable.
- Reach your hand through the access hole in the rear of the enclosure and snap the replacement RJ-11 connector onto the interior of the lower enclosure bezel plug-in.
- Reconnect the interior AC power cable.
- Use three tie wraps to bundle the power, CAT 6 and telephone cables (figure 1-7). Use the impressions in the remaining CAT 6 cable of the tie wraps that you cut in *Removing the Front Panel Connector*, step 1 as a guide for tie wrapping the bundle.

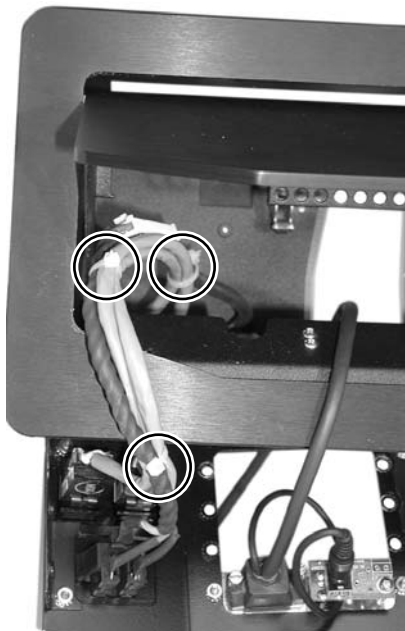

Bundle the CAT 6 and telephone cables at the circled locations.

Figure 1-7 — Bundling interior cables

Replacing the Front Panel Connector and Reassembling the HSA

- Snap the interior RJ-45 and RJ-11 connectors onto the rear of the front panel bezel plug-ins.
- Loosely place the front panel in the surface mount enclosure. Do not secure it in place at this time.
- Feed the cables connected to the AAPs in the HSA through the hole in the table and connect them to the devices that you disconnected them from in *Removing the HSA from the Table*, step 3 on page 1-4.
- Carefully lower the HSA enclosure into the table opening. From the underside, bolt the clamshell to the enclosure with the two bolts removed in *Removing the HSA from the Table*, step 4 on page 1-4.
- Connect the IEC power cord, the RJ-11, and RJ-45 cables to the connectors on the underside of the surface mount enclosure.
- Open and close the top panel while you experiment with the routing of the cable bundle. Find a routing that allows the top panel to open and close smoothly. If desired, use tie wraps to secure the bundled cables to the tie-down holes in the lower enclosure or on the mounting frame.
- Secure the front panel in place with the Allen screws removed in *Removing the Front Panel Connector*, step 3 on page 1-6.
- If desired, on the front panel, replace the connector icon by prying the old icon off of the bezel plug-in (figure 1-8) with a tweaker and snapping a new icon in place.

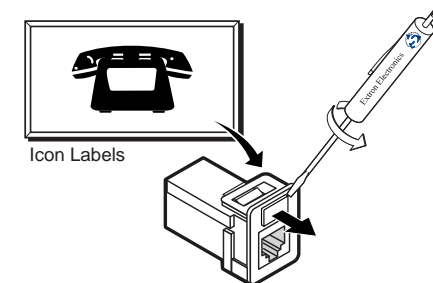
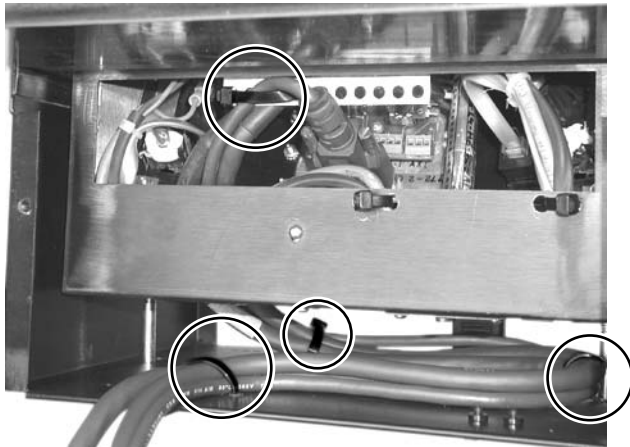

Figure 1-8 — Changing the connector icon

Routing the AAP Cables

1. Open the top panel to extend the AAP cables to their maximum pull.
2. Experiment with AAP cable positioning to ensure that the cables do not rub against the edges of the AAP cable hole and to ensure that the cable pull does not restrict the movement of the top panel. Figure 1-9 shows the cables routed to the side, which proved effective in tests at Extron.
3. Use tie wraps to secure the AAP cables to the tie-down holes in the clamshell and enclosure.

Rear View into HSA and Clamshell



Secure the AAP cables at the circled locations.

Figure 1-9 — HSA 402 AAP cable routing



RJ-45 to RJ-11 Conversion Kit

Chapter Two

HSA 800, 802, 822 Installation

Introduction

Removing the HSA from the Table

Replacing the Connectors

Reassembling the HSA

Routing the AAP Cables

HSA 800, 802, 822 Installation

Introduction

The Extron HSA 800, HSA 802, and HSA 822 ship with Category (CAT) 6 cables terminated with RJ-45 connectors between the front panel(s) and lower enclosure bezel plug-ins. Some users prefer a telephone (RJ-11) connector. This conversion kit consists of a length of telephone cable terminated with RJ-11 connectors to replace one of the CAT 6/RJ-45 cables.

Figure 2-1 shows the location of the bezel plug-ins on the underside and AAP panels of all versions of the HSA 802. The HSA 800 is identical, but with only one AAP panel and connectors A1 and A2 only. When replacing the CAT 6 cable, match front panel connector A1 with underside connector A1, match A2 with A2, and so forth.

NOTE Connectors B1 and B2 are present on the HSA 802 and HSA 822 only.

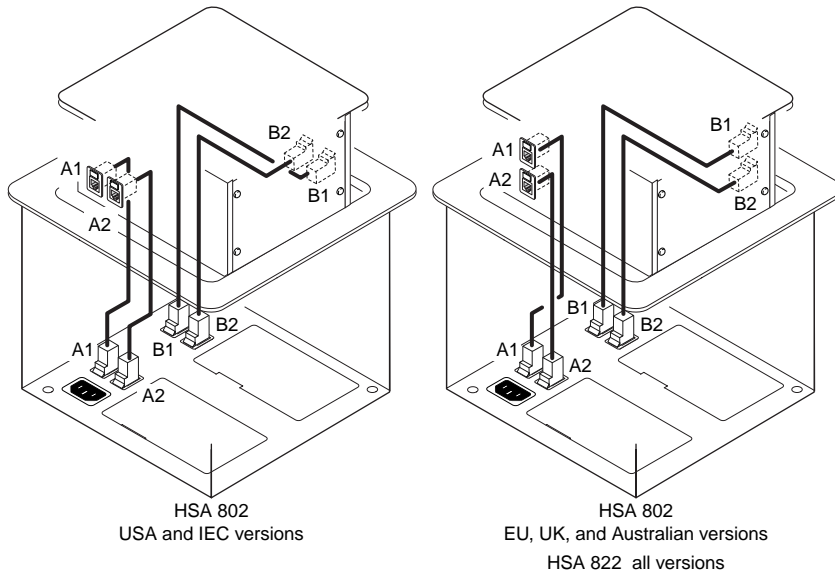

Figure 2-1 — Underside and front panel bezel plug-ins

Removing the HSA from the Table

WARNING Ensure that AC power is disconnected before servicing the HSA unit.

1. On the underside of the clamshell and in the enclosure, cut the tie wraps that route the AAP cables out of the way.
2. Disconnect the IEC power cord and RJ-45 connectors from the underside of the surface mount enclosure.
3. Disconnect any cables connected to the existing AAPs at the ends of the cables away from the HSAs.

WARNING The edges of the top panel are sharp. Exercise care when the HSA is removed from the table to prevent personal injury.

CAUTION The flanged edges of the top of the surface enclosure are bevelled to an ultra-fine thickness of less than 0.04 (4/100)'' (approximately 1 mm). These edges are soft and can be easily nicked or bent. Exercise caution when handling and mounting the enclosure. Mishandling can damage the appearance of the enclosure.

NOTE The surfaces of the HSA enclosure have screws and other protruding hardware that could damage fine furniture. Do not rest the enclosure on unprotected furniture.

- On the underside of the table, remove the two bolts that secure the clamshell to the surface mount enclosure (figure 2-2). Lift the enclosure out of the table. Ensure that the cables connected to the AAPs do not snag or pull on any protrusions.

NOTE Figure 2-2 shows an HSA 802. For the purposes of this procedure, the HSA 800 and HSA 822 are physically similar.

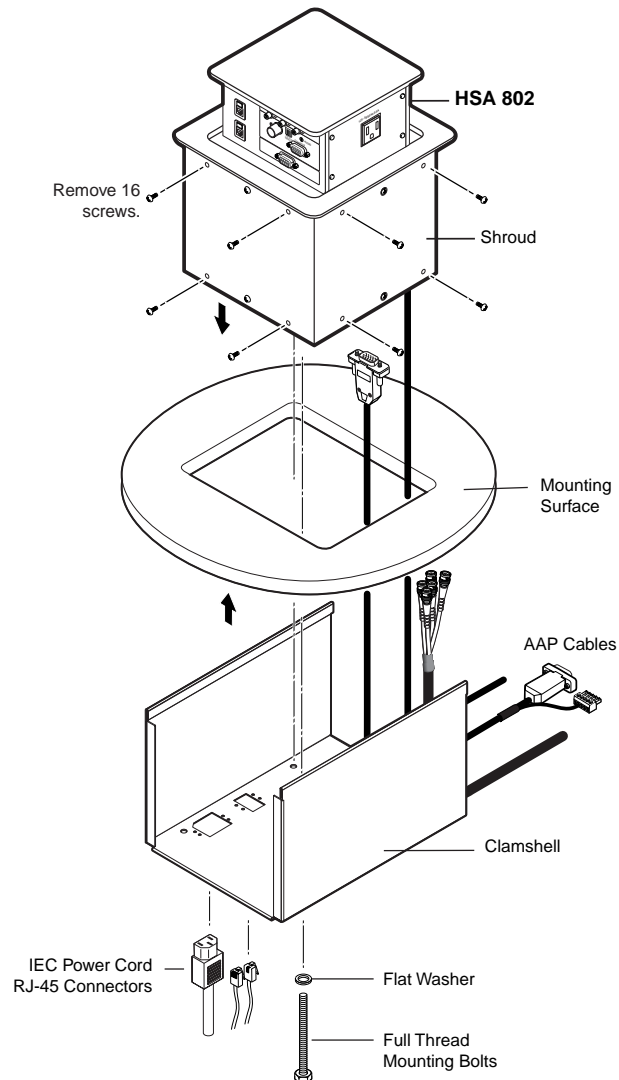

Figure 2-2 — Removing the HSA 802 from the table

- On all AAP panels, remove the four screws on the right and left sides of the AAP panel (figure 2-3). Retain the screws. Lift the panels away from the enclosure as far as the connected cables allow and then allow the panels to dangle, supported by their connected cables.

NOTE Ensure that the edges of the AAP panels do not scratch the finished surface of the top panel flange.

NOTE Figure 2-3 shows an HSA 802. For the purposes of this procedure, the HSA 800 and HSA 822 are physically similar.

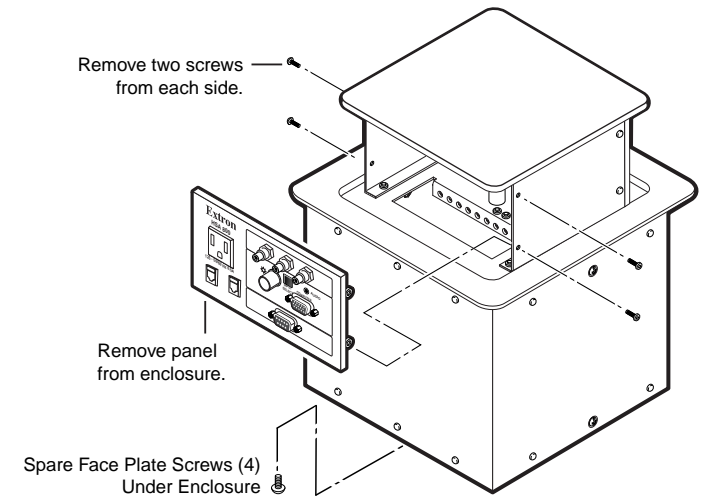

Figure 2-3 — Removing the connector/AAP panel

Replacing the Connectors

- Remove and retain the four screws in the corners of each side surface of the enclosure “cube”. Remove the two halves of the shroud.

NOTE Do not remove the screws in the center of each side.

- Cut the tie wraps that bundle the CAT 6 cables.

- Inside the AAP panel, identify the RJ-45 connector to be replaced. With a tweezers, push down on and gently twist on the front of the RJ-45 connector detent to disconnect the connector from the rear of the AAP panel bezel plug-in.

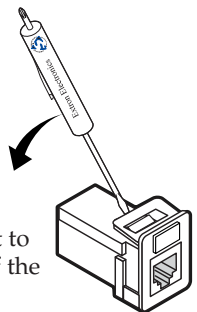

4. Inside the bottom frame, identify the RJ-45 connector to be replaced. With a tweaker, push down on and gently twist on the front of the RJ-45 connector detent to disconnect the connector from the bottom frame bezel plug-in.
5. Note how the disconnected CAT 6 cable is routed inside the HSA and then gently pull the cable free.
6. Route the conversion kit telephone cable in the same fashion as the removed CAT 6 cable.
7. Snap the replacement RJ-11 connectors on the conversion kit cable onto the interior of the AAP panel and lower frame bezel plug-ins.

Reassembling the HSA

1. Use tie wraps to bundle the CAT 6 and telephone cables (figure 2-4). Use the impressions in the remaining CAT 6 cable of the tie wraps that you cut in *Replacing the connectors*, step 2 on page 2-5 as a guide for placing the tie wraps.

NOTE Figure 2-4 shows an HSA 802. For the purposes of this procedure, the HSA 800 and HSA 822 are physically similar.

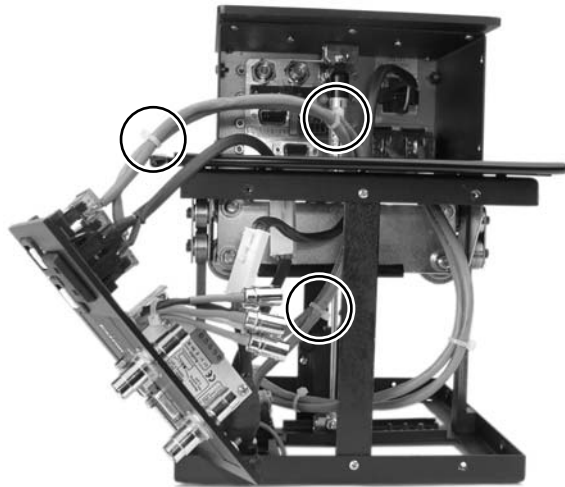

Bundle the CAT 6 and telephone cables at the circled locations.

Figure 2-4 — Bundling interior cables

2. Rest the AAP panels in place in the enclosure. Do not secure the panels in place at this time.

3. Open and close the top panel while you experiment with the routing of the cable bundle. Find a routing that allows the top panel to open and close smoothly. If desired, use tie wraps to secure the bundled cables to the tie-down holes in the lower enclosure or on the mounting frame.
4. Secure the two shroud halves to the enclosure frame with the eight screws (four per side) removed in *Replacing the Connectors*, step 1 on page 2-5.
5. Replace the AAP panels in the surface mount enclosure and secure them in place with the screws removed in *Removing the HSA from the Table*, step 5 on page 2-5.
6. Feed the cables connected to the AAPs in the HSA through the hole in the table and connect them to the devices that you disconnected them from in *Removing the HSA from the Table*, step 3 on page 2-3.
7. Carefully lower the HSA enclosure into the table opening. From the underside, bolt the clamshell to the enclosure with the two bolts removed in *Removing the HSA from the Table*, step 4 on page 2-4.
8. Connect the IEC power cord, the RJ-11, and RJ-45 cables to the connectors on the underside of the surface mount enclosure.
9. If desired, on the AAP panel, replace the connector icon by prying the old icon off of the bezel plug-in (figure 2-5) with a tweaker and snapping a new icon in place. If needed, four spare screws are stored in the underside of the enclosure.

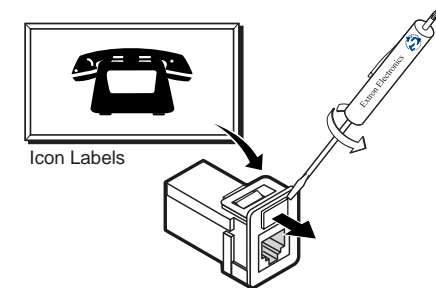

Figure 2-5 — Changing the connector icon

10. Open and close the top panel to check that the cables do not interfere with smooth operation or rub against sharp edges. If necessary, reach the cables through the cable access holes in the lower frame and experiment with the routing of the cable bundles. If desired, secure the cable bundles on the mounting frame with tie wraps.

Routing the AAP Cables

1. Open the top panel to extend the AAP cables to their maximum pull.
2. Experiment with AAP cable positioning to ensure that the cables do not rub against the edges of the AAP cable hole and to ensure that the cable pull does not restrict the movement of the top panel. Figure 2-6 shows the cables routed to the side, which proved effective in tests at Extron.

NOTE *Figure 2-6 shows an HSA 822. For the purposes of this procedure, the HSA 800 and HSA 802 are physically similar.*

View from one side

View from the opposite side

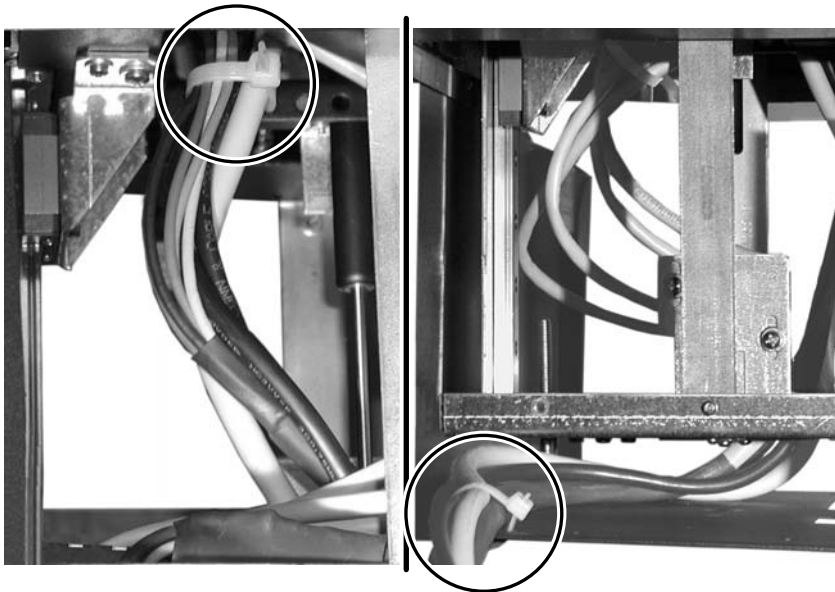

Secure the AAP cables at the circled locations.

Figure 2-6 — HSA 822 AAP cable routing

3. Use tie wraps to secure the AAP cables to the tie-down holes in the clamshell and enclosure.