

Installation

- Remove and retain the four screws that secure the lower enclosure to the flange and top panel assembly, then turn the enclosure onto its back side (see Figure 4).

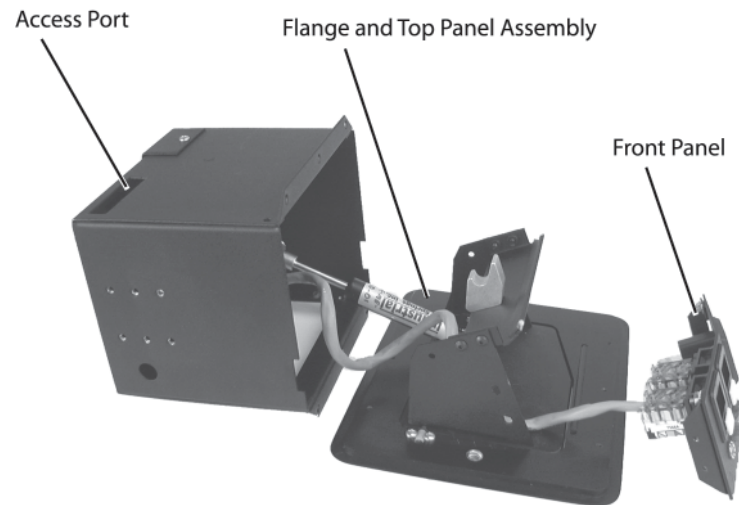

Figure 4 — Open enclosure with front panel removed

- Separate the flange and top panel assembly from the lower enclosure and lay it flat on the work surface.
- Remove and retain the four Allen screws on the right and left sides of the front panel and lift the panel away from the enclosure.
- With a tweezers, push down on and gently twist on the front of the RJ-45 connector detent to disconnect the connector from the rear of the front panel bezel plug-in.

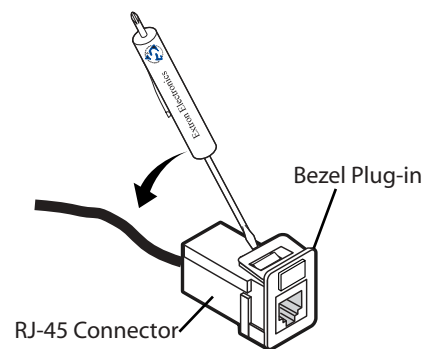

Figure 5 — Removing the RJ-45 connector from the bezel plug-in

Installation, cont'd

- Through the access port (see figure 4), with a tweezers, push down on and gently twist on the front of the RJ-45 connector detent to disconnect the connector from the lower enclosure bezel plug-in.
- Remove the RJ-45 connectors and attached CAT 6 cable from the enclosure, noting where the cable is routed and secured.
- Snap the replacement RJ-11 connector and attached phone cable onto the interior of the lower enclosure bezel plug-in.
- Route the cable as previously noted, securing where necessary.
- Replace the front panel in the enclosure and secure it in place with the Allen screws removed in step 6.
- Tip the flange and top panel assembly up to meet the lower enclosure, guiding the gas lift through the hole in the lower enclosure, and align the screw holes. Allow the top door to hang open.
- Secure the flange and top panel assembly to the lower enclosure with the four screws removed in step 4.
- Secure the gas lift in the clevis on the gas lift mounting bracket with the nut and pivot bolt removed in step 3.
- Firmly push the gas lift mounting plate into position on the underside of the enclosure, engaging the three mounting screws. Holding the plate in position, secure it to the enclosure with the three screws that were loosened in step 1.
- Raise and lower the top several times to ensure that the mechanism moves freely. If the new cable binds the mechanism, remove the flange and top panel assembly and resecure the cable to clear the obstruction.

Replacing the HSA enclosure

- Carefully lower the HSA enclosure into the table opening. From the underside, reattach the screw clamps to both sides of the enclosure, then tighten the screw clamps, securing the enclosure to the tabletop.
- Reconnect the IEC power cord, the power supply connector (200SE and 200CE), the BNC (video) connectors, the audio connector, and the RJ-45/RJ-11 connectors to the underside of the enclosure.

Extron® Electronics
INTERFACING, SWITCHING AND DISTRIBUTION



User's Guide



RJ-45 to RJ-11 Conversion Kit HSA 200 Series



Extron Electronics, USA
1230 South Lewis Street
Anaheim, CA 92805
USA
714.491.1500
Fax 714.491.1517

Extron Electronics, Europe
Beeldschermweg 6C
3821 AH Amersfoort
The Netherlands
+31.33.453.4040
Fax +31.33.453.4050

Extron Electronics, Asia
135 Joo Seng Road, #04-01
PM Industrial Building
Singapore 368363
+65.6383.4400
Fax +65.6383.4664

Extron Electronics, Japan
Daisan DMJ Building 6F
3-9-1 Kudan Minami
Chiyoda-ku, Tokyo 102-0074 Japan
+81.3.3511.7655
Fax +81.3.3511.7656

© 2003 Extron Electronics. All rights reserved.

Introduction

The Extron HSA 200S, 200SE, 200C, and 200CE ship with Category (CAT) 6 cable terminated with RJ-45 connectors between the front panel and the bottom of the enclosure. These RJ-45 connectors fit into small plastic bezel plug-ins which, in turn, fit into the front panel and bottom of the enclosure. The conversion kit (#70-231-01) consists of a length of telephone cable, terminated with RJ-11 connectors, to replace the CAT 6 cable/RJ-45 connectors.

Figure 1 shows the location of the bezel plug-ins on the front panel of the HSA 200. Figure 2 shows the associated connectors on the bottom of the HSAs. When replacing the CAT 6 cable, match the front panel connection (A) with the underside connector (A), match (B) with (B), and so forth.

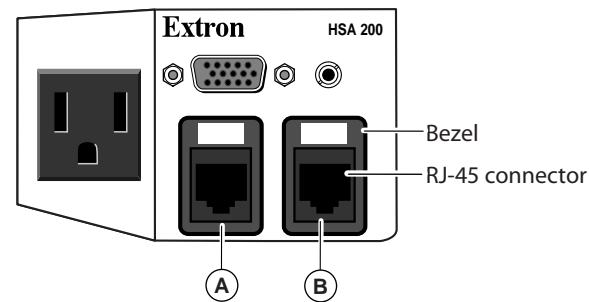

Figure 1 - HSA 200 front panel

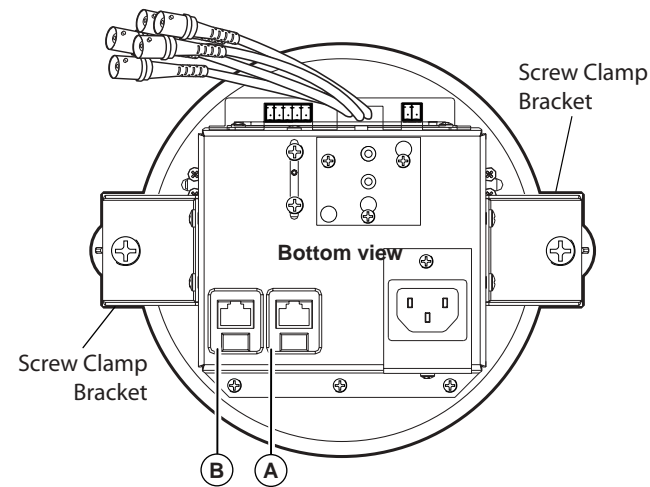

Figure 2 - HSA 200 bottom features

Installation Overview

Remove the RJ-45 connector/cable and replace with the RJ-11 connector/cable as follows:

- 1 Disconnect the IEC power cord, the RJ-45 connectors, and other cables from the HSA 200.
- 2 Remove the HSA 200 from the table in which it is installed.
- 3 Remove the flange and top panel assembly and the front panel.
- 4 Remove the RJ-45 connector/cable from the front panel bezel plug-in and the bottom bezel plug-in.
- 5 Install the RJ-11 connector/cable into the front panel bezel plug-in and the bottom bezel plug-in.
- 6 Reinstall the HSA 200 in the table surface.
- 7 Connect the power, video, audio, RJ-11 and/or RJ-45 cables to the underside of the enclosure.

Removing the HSA Enclosure

The procedures for changing the RJ-45 connector/cable require removing the HSA 200 from the table. Remove the surface mount enclosure as follows:

WARNING Ensure that AC power is disconnected before servicing the HSA unit.

- 1 Disconnect the IEC power cord, the power supply connector (200CE and 200SE), the BNC (video) connectors, the audio connector, and the RJ-45 connectors from the underside of the surface mount enclosure.
- 2 On the underside of the table, loosen the two screw clamps holding the enclosure to the tabletop. Remove the two screw clamp brackets (see figure 2).
- 3 Lift the enclosure out of the table.

CAUTION The edges of the top panel are sharp. Exercise care when handling the HSA to prevent personal injury.

The flanged edges of the top of the surface enclosure are bevelled to an ultra-fine thickness of less than 0.04 (4/100)'' (approximately 1 mm), and are therefore very sharp. These edges are also soft and may be easily nicked or bent. Exercise caution when handling and mounting the enclosure. Mishandling may result in injury to the installer or damage the appearance of the enclosure.

Installation

NOTE The surfaces of the HSA enclosure have screws and other protrusions that could damage fine furniture. Do not rest the enclosure on unprotected furniture.

- 4 Place the enclosure on a flat work surface, on a soft cloth or pad to protect the finish.

Replacing the RJ-45 Connectors

After removing the HSA 200 enclosure from the table, replace the RJ-45 connector/cable as follows:

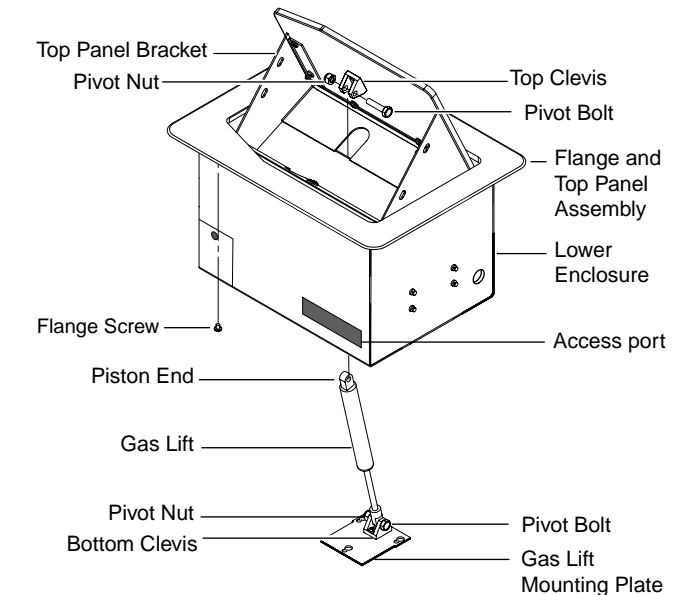

Figure 3 — Disconnect the gas lift and remove the top

CAUTION The gas lift strongly pushes its mounting plate away from the underside of the enclosure. Hold the plate firmly against the enclosure while loosening the screws to prevent the plate from being bent by the pressure of the gas lift.

- 1 Turn the enclosure upside down. Loosen the three Philips head screws that secure the gas lift mounting plate in place.
- 2 Slide the gas lift mounting plate toward the center of the enclosure, releasing the mounting plate from the enclosure.
- 3 Remove the pivot nut from the lower pivot bolt, then remove the bolt, releasing the lower end of the gas lift from the gas lift mounting plate.