

VTG 300/300R

Video and Audio Test Generator



Extron® Electronics
INTERFACING, SWITCHING AND CONTROL

Safety Instructions • English



This symbol is intended to alert the user of important operating and maintenance (servicing) instructions in the literature provided with the equipment.



This symbol is intended to alert the user of the presence of uninsulated dangerous voltage within the product's enclosure that may present a risk of electric shock.

Caution

Read Instructions • Read and understand all safety and operating instructions before using the equipment.

Retain Instructions • The safety instructions should be kept for future reference.

Follow Warnings • Follow all warnings and instructions marked on the equipment or in the user information.

Avoid Attachments • Do not use tools or attachments that are not recommended by the equipment manufacturer because they may be hazardous.

Consignes de Sécurité • Français



Ce symbole sert à avertir l'utilisateur que la documentation fournie avec le matériel contient des instructions importantes concernant l'exploitation et la maintenance (réparation).



Ce symbole sert à avertir l'utilisateur de la présence dans le boîtier de l'appareil de tensions dangereuses non isolées posant des risques d'électrocution.

Attention

Lire les instructions • Prendre connaissance de toutes les consignes de sécurité et d'exploitation avant d'utiliser le matériel.

Conserver les instructions • Ranger les consignes de sécurité afin de pouvoir les consulter à l'avenir.

Respecter les avertissements • Observer tous les avertissements et consignes marqués sur le matériel ou présentés dans la documentation utilisateur.

Éviter les pièces de fixation • Ne pas utiliser de pièces de fixation ni d'outils non recommandés par le fabricant du matériel car cela risquerait de poser certains dangers.

Sicherheitsanleitungen • Deutsch



Dieses Symbol soll dem Benutzer in der im Lieferumfang enthaltenen Dokumentation besonders wichtige Hinweise zur Bedienung und Wartung (Instandhaltung) geben.



Dieses Symbol soll den Benutzer darauf aufmerksam machen, daß im Inneren des Gehäuses dieses Produktes gefährliche Spannungen, die nicht isoliert sind und die einen elektrischen Schock verursachen können, herrschen.

Achtung

Lesen der Anleitungen • Bevor Sie das Gerät zum ersten Mal verwenden, sollten Sie alle Sicherheits- und Bedienungsanleitungen genau durchlesen und verstehen.

Aufbewahren der Anleitungen • Die Hinweise zur elektrischen Sicherheit des Produktes sollten Sie aufbewahren, damit Sie im Bedarfsfall darauf zurückgreifen können.

Befolgen der Warnhinweise • Befolgen Sie alle Warnhinweise und Anleitungen auf dem Gerät oder in der Benutzerdokumentation.

Keine Zusatzgeräte • Verwenden Sie keine Werkzeuge oder Zusatzgeräte, die nicht ausdrücklich vom Hersteller empfohlen wurden, da diese eine Gefahrenquelle darstellen können.

Instrucciones de seguridad • Español



Este símbolo se utiliza para advertir al usuario sobre instrucciones importantes de operación y mantenimiento (o cambio de partes) que se desean destacar en el contenido de la documentación suministrada con los equipos.



Este símbolo se utiliza para advertir al usuario sobre la presencia de elementos con voltaje peligroso sin protección aislante, que puedan encontrarse dentro de la caja o alojamiento del producto, y que puedan representar riesgo de electrocución.

Precaución

Leer las instrucciones • Leer y analizar todas las instrucciones de operación y seguridad, antes de usar el equipo.

Conservar las instrucciones • Conservar las instrucciones de seguridad para futura consulta.

Obedecer las advertencias • Todas las advertencias e instrucciones marcadas en el equipo o en la documentación del usuario, deben ser obedecidas.

Evitar el uso de accesorios • No usar herramientas o accesorios que no sean específicamente recomendados por el fabricante, ya que podrían implicar riesgos.

安全须知 • 中文



这个符号提示用户该设备用户手册中有重要的操作和维护说明。



这个符号警告用户该设备机壳内有暴露的危险电压，有触电危险。

注意

阅读说明书 • 用户使用该设备前必须阅读并理解所有安全和使用说明。

保存说明书 • 用户应保存安全说明书以备将来使用。

遵守警告 • 用户应遵守产品和用户指南上的所有安全和操作说明。

避免追加 • 不要使用该产品厂商没有推荐的工具或追加设备，以避免危险。

Warning

Power sources • This equipment should be operated only from the power source indicated on the product. This equipment is intended to be used with a main power system with a grounded (neutral) conductor. The third (grounding) pin is a safety feature, do not attempt to bypass or disable it.

Power disconnection • To remove power from the equipment safely, remove all power cords from the rear of the equipment, or the desktop power module (if detachable), or from the power source receptacle (wall plug).

Power cord protection • Power cords should be routed so that they are not likely to be stepped on or pinched by items placed upon or against them.

Servicing • Refer all servicing to qualified service personnel. There are no user-serviceable parts inside. To prevent the risk of shock, do not attempt to service this equipment yourself because opening or removing covers may expose you to dangerous voltage or other hazards.

Slots and openings • If the equipment has slots or holes in the enclosure, these are provided to prevent overheating of sensitive components inside. These openings must never be blocked by other objects.

Lithium battery • There is a danger of explosion if battery is incorrectly replaced. Replace it only with the same or equivalent type recommended by the manufacturer. Dispose of used batteries according to the manufacturer's instructions.

Avertissement

Alimentations • Ne faire fonctionner ce matériel qu'avec la source d'alimentation indiquée sur l'appareil. Ce matériel doit être utilisé avec une alimentation principale comportant un fil de terre (neutre). Le troisième contact (de mise à la terre) constitue un dispositif de sécurité : n'essayez pas de la contourner ni de la désactiver.

Déconnexion de l'alimentation • Pour mettre le matériel hors tension sans danger, déconnectez tous les cordons d'alimentation de l'arrière de l'appareil ou du module d'alimentation de bureau (s'il est amovible) ou encore de la prise secteur.

Protection du cordon d'alimentation • Acheminer les cordons d'alimentation de manière à ce que personne ne risque de marcher dessus et à ce qu'ils ne soient pas écrasés ou pincés par des objets.

Réparation-maintenance • Faire exécuter toutes les interventions de réparation-maintenance par un technicien qualifié. Aucun des éléments internes ne peut être réparé par l'utilisateur. Afin d'éviter tout danger d'électrocution, l'utilisateur ne doit pas essayer de procéder lui-même à ces opérations car l'ouverture ou le retrait des couvercles risquent de l'exposer à de hautes tensions et autres dangers.

Fentes et orifices • Si le boîtier de l'appareil comporte des fentes ou des orifices, ceux-ci servent à empêcher les composants internes sensibles de surchauffer. Ces ouvertures ne doivent jamais être bloquées par des objets.

Lithium Batterie • Il a danger d'explosion s'il y a un remplacement incorrect de la batterie. Remplacer uniquement avec une batterie du même type ou d'un type équivalent recommandé par le constructeur. Mettre au rebut les batteries usagées conformément aux instructions du fabricant.

Vorsicht

Stromquellen • Dieses Gerät sollte nur über die auf dem Produkt angegebene Stromquelle betrieben werden. Dieses Gerät wurde für eine Verwendung mit einer Hauptstromleitung mit einem geerdeten (neutralen) Leiter konzipiert. Der dritte Kontakt ist für einen Erdschluß, und stellt eine Sicherheitsfunktion dar. Diese sollte nicht umgangen oder außer Betrieb gesetzt werden.

Stromunterbrechung • Um das Gerät auf sichere Weise vom Netz zu trennen, sollten Sie alle Netzkabel aus der Rückseite des Gerätes, aus der externen Stromversorgung (falls dies möglich ist) oder aus der Wandsteckdose ziehen.

Schutz des Netzkabels • Netzkabel sollten stets so verlegt werden, daß sie nicht im Weg liegen und niemand darauf treten kann oder Objekte darauf- oder unmittelbar dagegengestellt werden können.

Wartung • Alle Wartungsmaßnahmen sollten nur von qualifiziertem Servicepersonal durchgeführt werden. Die internen Komponenten des Gerätes sind wartungsfrei. Zur Vermeidung eines elektrischen Schocks versuchen Sie in keinem Fall, dieses Gerät selbst öffnen, da beim Entfernen der Abdeckungen die Gefahr eines elektrischen Schlags und/oder andere Gefahren bestehen.

Schlitze und Öffnungen • Wenn das Gerät Schlitze oder Löcher im Gehäuse aufweist, dienen diese zur Vermeidung einer Überhitzung der empfindlichen Teile im Inneren. Diese Öffnungen dürfen niemals von anderen Objekten blockiert werden.

Lithium-Batterie • Explosionsgefahr, falls die Batterie nicht richtig ersetzt wird. Ersetzen Sie verbrauchte Batterien nur durch den gleichen oder einen vergleichbaren Batterietyp, der auch vom Hersteller empfohlen wird. Entsorgen Sie verbrauchte Batterien bitte gemäß den Herstelleranweisungen.

Advertencia

Alimentación eléctrica • Este equipo debe conectarse únicamente a la fuente/tipo de alimentación eléctrica indicada en el mismo. La alimentación eléctrica de este equipo debe provenir de un sistema de distribución general con conductor neutro a tierra. La tercera pata (puesta a tierra) es una medida de seguridad, no puentearla ni eliminarla.

Desconexión de alimentación eléctrica • Para desconectar con seguridad la acometida de alimentación eléctrica al equipo, desenchufar todos los cables de alimentación en el panel trasero del equipo, o desenchufar el módulo de alimentación (si fuera independiente), o desenchufar el cable del receptáculo de la pared.

Protección del cables de alimentación • Los cables de alimentación eléctrica se deben instalar en lugares donde no sean pisados ni apretados por objetos que se puedan apoyar sobre ellos.

Reparaciones/mantenimiento • Solicitar siempre los servicios técnicos de personal calificado. En el interior no hay partes a las que el usuario deba acceder. Para evitar riesgo de electrocución, no intentar personalmente la reparación/mantenimiento de este equipo, ya que al abrir o extraer las tapas puede quedar expuesto a voltajes peligrosos u otros riesgos.

Ranuras y aberturas • Si el equipo posee ranuras o orificios en su caja/alojamiento, es para evitar el sobrecalentamiento de componentes internos sensibles. Estas aberturas nunca se deben obstruir con otros objetos.

Batería de litio • Existe riesgo de explosión si esta batería se coloca en la posición incorrecta. Cambiar esta batería únicamente con el mismo tipo (o su equivalente) recomendado por el fabricante. Desachar las baterías usadas siguiendo las instrucciones del fabricante.

警告

电源 • 该设备只能使用产品上标明的电源。设备必须使用有地线的供电系统供电。第三条线（地线）是安全设施，不能不用或跳过。

拔掉电源 • 为安全地从设备拔掉电源，请拔掉所有设备后或桌面电源的电源线，或任何接到市电系统的电源线。

电源线保护 • 妥善布线，避免被踩踏，或重物挤压。

维护 • 所有维修必须由认证的维修人员进行。设备内部没有用户可以更换的零件。为避免出现触电危险不要自己试图打开设备盖子维修该设备。

通风孔 • 有些设备机壳上有通风槽或孔，它们是用来防止机内敏感元件过热。不要有任何东西挡住通风孔。

锂电池 • 不正确的更换电池会有爆炸的危险。必须使用与厂家推荐的相同或相近型号的电池。按照生产厂的建议处理废弃电池。

FCC Class A Notice

This equipment has been tested and found to comply with the limits for a Class A digital device, pursuant to part 15 of the FCC Rules. Operation is subject to the following two conditions:

1. This device may not cause harmful interference.
2. This device must accept any interference received, including interference that may cause undesired operation.

The Class A limits are designed to provide reasonable protection against harmful interference when the equipment is operated in a commercial environment. This equipment generates, uses, and can radiate radio frequency energy and, if not installed and used in accordance with the instruction manual, may cause harmful interference to radio communications. Operation of this equipment in a residential area is likely to cause harmful interference, in which case the user will be required to correct the interference at his own expense.

NOTE: This unit was tested with shielded cables on the peripheral devices. Shielded cables must be used with the unit to ensure compliance with FCC emissions limits.

For more information on safety guidelines, regulatory compliances, EMI/EMF compliance, accessibility, and related topics, [click here](#).

Conventions Used in this Guide

Notifications

In this user guide, the following are used:

WARNING: A warning warns of things or actions that might cause injury, death, or other severe consequences.

CAUTION: A caution indicates a potential hazard to equipment or data.

NOTE: A note draws attention to important information.

TIP: A tip provides a suggestion to make working with the application easier.

Copyright

© 2011 Extron Electronics. All rights reserved.

Trademarks

All trademarks mentioned in this guide are the properties of their respective owners.

Contents

Introduction	1
About the VTG 300/300R	1
Features.....	1

Operation	2
Front Panel Features.....	2
Left Side Panel LED (VTG 300R model only).....	4
Right Side Panel Power Input	4
Top Panel Video Output	4
Bottom Panel Audio Output.....	4
Example Applications	5
Connecting Audio Outputs	5
Menus, Configuration, and Adjustments.....	6
Moving Through Menus by Using Front Panel Controls.....	6
Default Menu	6
Main Menu	7
Test Pattern Setup Menu	7
Audio Setup Menu.....	8
Video Setup Menu	9
Advanced Setup Menu.....	10
Exit Menu	13
Additional Functions	13
Low Battery Mode	13
Button Lock Mode	14
Audio Testing Features	15
Selecting Audio Signals.....	15
Setting the Audio Level	15
Setting the Audio Frequency	16
Video Testing Features	16
Selecting a Video Test Pattern	18
Selecting a Signal Range	19
Setting the Scan Rate.....	19
Installing the VTG 300 Batteries	20
Conserving the VTG 300 Battery Life.....	21
Recharging the VTG 300R.....	21
Installing the Protective Boot.....	22

Reference Information	23
Specifications.....	23
Included Parts	25

Extron Warranty	26
------------------------------	----

Introduction

This section provides an **overview** of the VTG 300 and VTG 300R and describes their **features**.

About the VTG 300/300R

The Extron VTG 300 and the VTG 300R are portable, hand-held video and audio test generators. The VTG 300R features an integrated battery pack and charger, otherwise both models offer the same functions and features. “VTG” and “video test generator” refer to both the VTG 300 and the VTG 300R and are used interchangeably.

The VTG will generate video signals for computer, standard resolution video, HDTV, and 16:9 high resolution output rates. The composite video format conforms to the SMPTE 170M video standard. There are also six test pattern categories available for optimizing the display output: crosshatch, H pattern, color bars, grayscale, alternating pixels/multiburst, and white field.

For audio signals, the VTG offers basic audio test signals including sine and square waves, pink noise, white noise, polarity testing, and a frequency sweep from 20 Hz to 20 kHz.

Video output connectors include BNC, 4-pin mini DIN, and 15-pin HD connectors. Audio output is provided through RCA, 3-pin XLR, and 3.5 mm phone jack connectors.

The VTG 300 is powered by the included external power supply or four AA-type batteries (not included).

The VTG 300R is powered by both the included external power supply and the built-in rechargeable batteries.

Features

- **Multiple video outputs** — Video output rates include:
 - Computer video (RGB)
 - Standard definition video (NTSC/PAL) – composite, S-video, component video, or RGB
 - HDTV (component, RGB)
 - 16:9 high resolution (RGB)
- **Scan rates and test patterns** — The VTG outputs 43 different scan rates and offers 13 different test patterns in six categories.
- **Multiple audio outputs** — Audio output is provided through RCA, 3-pin XLR, and 3.5 mm phone jack connectors.
- **Automatic recall** — Whenever the VTG is powered down, the most recent settings are saved and then recalled when the unit is powered back up.
- **Protective boot** — To help protect the VTG from physical damage, a special protective rubber boot is included.

Operation

This section describes:

- **Front Panel Features**
- **Left Side Panel LED (VTG 300R model only)**
- **Right Side Panel Power Input**
- **Top Panel Video Output**
- **Bottom Panel Audio Output**
- **Example Applications**
- **Connecting Audio Outputs**
- **Menus, Configuration, and Adjustments**
- **Additional Functions**
- **Audio Testing Features**
- **Video Testing Features**
- **Installing the VTG 300 Batteries**
- **Conserving the VTG 300 Battery Life**
- **Recharging the VTG 300R**
- **Installing the Protective Boot**

Front Panel Features

- **LCD Display**— A two-row liquid crystal display for viewing the VTG status, menus, and options.

Audio buttons (left side):

- **Signal Button (audio signal type)** — Press this button to select from among six different audio signals, as indicated by green LEDs to the right:

- Pink noise (P. Noise)
- White noise (W. Noise)
- Sine wave (Sine)
- Square wave (Square)
- Polarity test (Polarity)
- Swept sine wave (Sweep)

- **Level Buttons (audio output signal level adjustment)** — Press the ▲ button to increase the RMS signal level and the ▼ button to decrease the RMS signal level.

See the **Audio Setup menu** section to specify either dBu or dBV as the signal level unit.

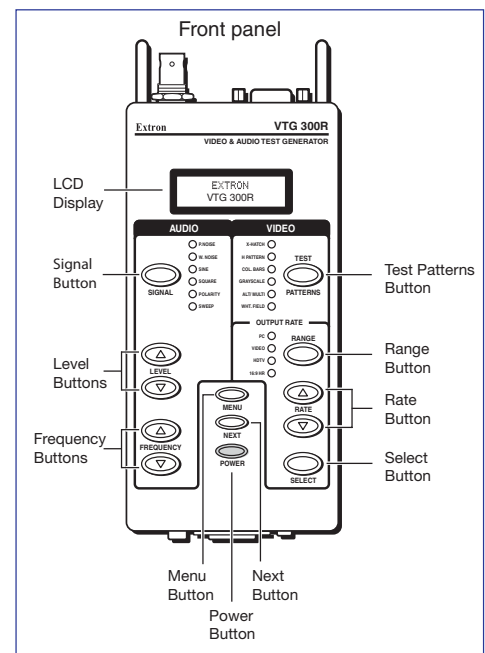

The audio output level settings for all **audio signal types** are retained after the VTG is powered off. The default setting is -28 dBu for polarity and -10 dBu for all other signal types.

NOTE: If the **Level** buttons are held down for more than one second, the VTG will automatically increment the level adjustment in the direction indicated by the button.

- **Frequency (audio frequency adjustment)** — When the audio signal type is either a sine or square wave (see **audio signal type**, above), the audio frequency can be adjusted from 20 Hz to 20 kHz (sine) or 20 Hz to 5 kHz (square). Press the ▲ button to increase the frequency and the ▼ button to decrease the frequency. The adjustment is in 1/3 octave steps (see **Setting the audio frequency**).

Menu, Next and Power buttons (bottom center):

- **Menu Button (menu selection)** — Press the Menu button to advance through the four main menus (see the **Menus, Configuration, and Adjustments**).
- **Next Button** — Press the Next button to step through the submenus. (see the **Menus, Configuration, and Adjustments**).
- **Power Button** — Power up or power down the VTG 300 by holding down the **Power** button for one second.

NOTE: If the **Power** button is held down for more than three seconds, the VTG will automatically turn off. This feature will prevent the VTG from being left on unintentionally should the power button be unknowingly pressed.

Video buttons (right side):

- **Test Patterns Button (video test patterns)** — Press this button to select from among 13 different test patterns in six categories (see **Selecting a Video Test Pattern**), as indicated by green LEDs to the left of each category:
 - crosshatch (X-hatch)
 - H pattern
 - color bars (Col. Bars)
 - grayscale
 - alternating pixels/multiburst (Alt./Multi)
 - white field (Wht. Field)
- **Range Button (video output range)** — Select the video output signal range, as indicated by green LEDs to the left: computer scan rates (PC), video scan rates (Video), HDTV scan rates (HDTV), or 16:9 HR scan rates.
- **Rate Button (video output rate adjustment)** — Press the ▲ button or ▼ button to vary the scan rate for a selected output range.
- **Select (video output rate)** — Select and activate the desired output rate for a given range by pressing this button.

Left Side Panel LED (VTG 300R model only)

Battery charge status LED — The amber LED lights steadily when the VTG is being charged, and blinks steadily when the VTG is fully charged.

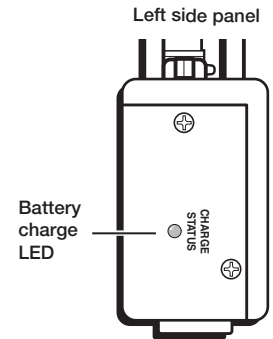

Right Side Panel Power Input

12 VDC power input — The included external 12 VDC, 100 VAC to 240 VAC, 50/60 Hz power supply plugs into this connector located on the right side panel.

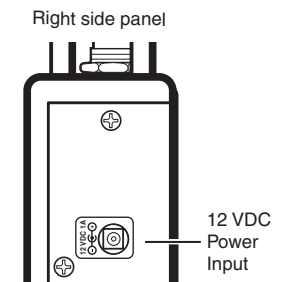

Top Panel Video Output

RGB/R-Y, Y, B-Y output — RGBHV, RGBS, RGsB, RsGsBs, and component video are output through the 15-pin HD connector.

NOTE: For NTSC/PAL rates, the component video output is intended for signal verification and alignment, and should not be used as a reference.

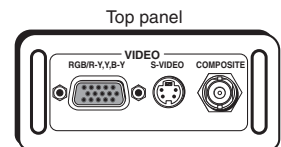

S-video output — S-video is output through the 4-pin mini DIN connector.

Composite video output — Composite video is output through the BNC connector.

Bottom Panel Audio Output

Output 1: RCA jack — Unbalanced mono audio is output from this female jack.

Output 2: 3-pin XLR connector — Balanced mono audio is output from this male connector.

Output 3: 3.5 mm mini stereo phone jack — Unbalanced mono audio on both left and right channels is output from this female mini phone jack.

NOTE: See [Connecting Audio Outputs](#) for audio wiring instructions.

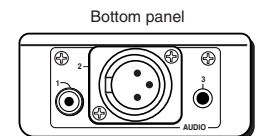

Example Applications

Figure 1 shows examples using the video and audio testing features of the VTG.

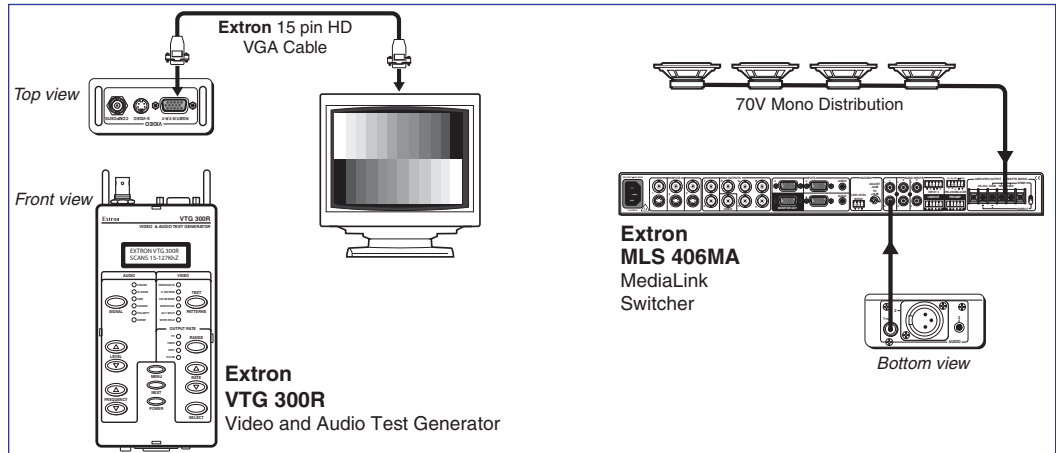

Figure 1. Using the Video and Audio Testing Features

Connecting Audio Outputs

The VTG has three types of audio output connectors: an RCA jack, a 3-pin XLR connector, and a 3.5 mm mini stereo phone jack.

Output 1

Unbalanced mono audio is output from this connector. Wire the RCA connector as shown here.

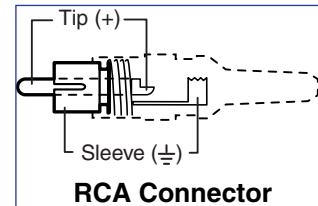

Output 2

Balanced mono audio is output from this connector. Wire the female XLR connector as shown here.



3-pin XLR Pin Configuration			
Application	Pin 1	Pin 2	Pin 3
Balanced audio (std.)	gnd (shield) (on sending female connector)	positive (+) (hot/live)	negative (-) (cold/return)

Output 3

Unbalanced mono audio on both left and right channels is output from this connector. Wire the mini phono plug as shown here (see the [Output 3 submenu](#) section on page 8).

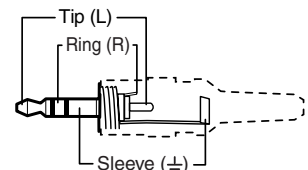

Menus, Configuration, and Adjustments

VTG configuration and adjustments are performed by using the front panel controls and the menus that are displayed on the LCD screen.

Moving Through Menus by Using Front Panel Controls

- **Menu button** — Press the Menu button to step through the main menus. After 20 seconds of inactivity, the VTG will time-out and return to the default menu cycle.
- **Next button** — Press the Next button to move between the submenus of a selected main menu.
- **Up (▲) and Down (▼) buttons** — Use any of these buttons (Level, Frequency, or Rate), to increase (▲) or decrease (▼) submenu values, or to alternate between submenu options. Refer to the flowcharts in this chapter and to specific sections for explanations on submenu adjustments.

Default Menu

The default menus appear on the LCD when no adjustments are actively being made. They cycle between the screens showing the currently selected horizontal scan frequency of the video output signal, the audio output level, and the audio frequency, as shown below.

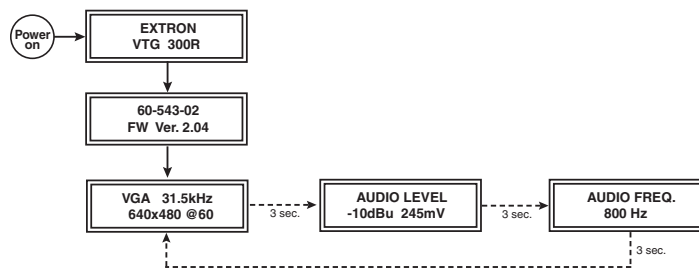
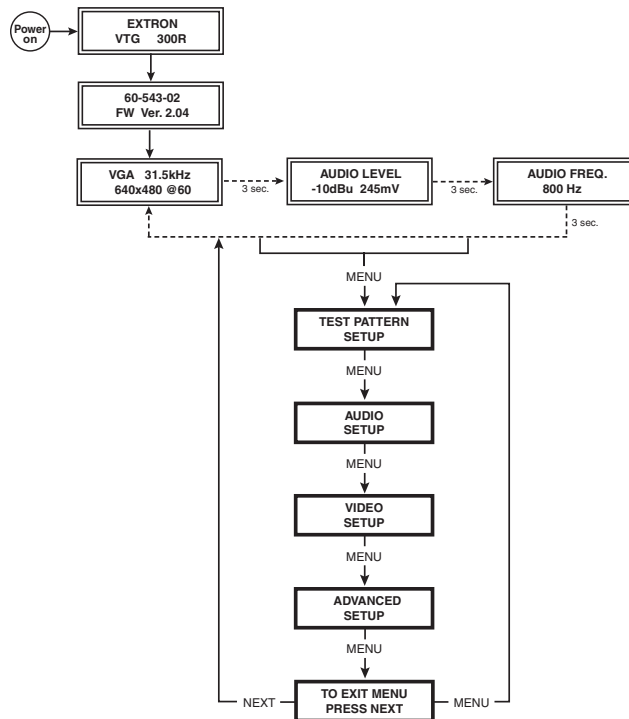

Figure 2. Default Menu Cycle

- NOTES:**
- From any menu or submenu, after 20 seconds of inactivity the VTG will save all adjustment settings and time out to the default menus.
 - A different default menu is displayed when the screen saver option is active (see [Screen saver timer submenu \(ScrSvr Timer\)](#) on page 10).
 - If an output was disabled at power up, the menu will display “Audio disabled” or “Video disabled” instead of the normal menu (see [Enable at power up submenu \(Enable@PwrUp\)](#) on page 12).

Main Menu

The main menus are shown in the following flowchart. Use the **Menu** button to step between main menus.



- NOTES:**
- If you press the **Menu** button while a submenu is active, the next main menu will become active
 - To return to the default menu cycle, let the VTG time-out for 20 seconds, or press the **Menu** button until the **Exit Menu** menu appears, then press the **Next** button.

Figure 3. Main Menus for the VTG 300/300R

Test Pattern Setup Menu

The following flowchart illustrates the **Test Pattern Setup** menu.

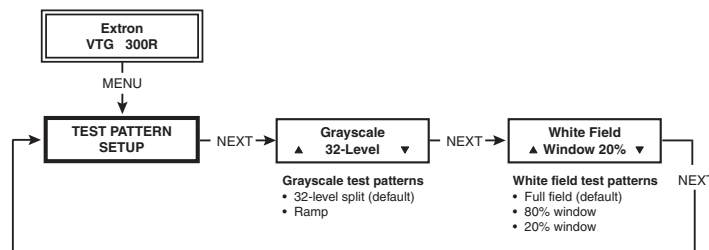

Figure 4. Test Pattern Setup Menu

Grayscale submenu

Select the grayscale test pattern from among two types.

Press any **▲** or **▼** button to select from the different test patterns:

- **32-level split bars (default)** — to set grayscale tracking and evaluate contrast linearity.
- **Ramp** — to evaluate pixel bit depth capability.

White field submenu

There are three types of white field test patterns.

Press any ▲ or ▼ button to select the test pattern:

- **Full field (default)** — evaluate white field and color uniformity.
- **80% window** — fine tune color balance and gain (drive) for each of the red, green, and/or blue color adjustments.
- **20% window** — fine tune color balance and bias (offset) for each of the red, green, or blue color adjustments.

Audio Setup Menu

The following flowchart illustrates the **Audio Setup** menu.

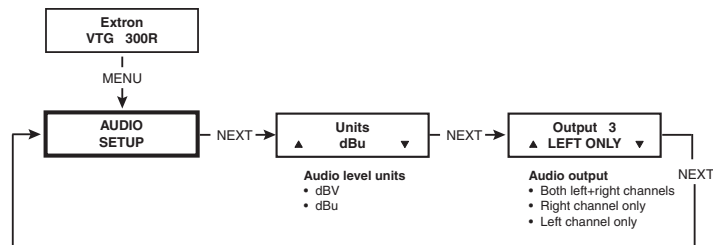

Figure 5. Audio Setup Menu

Audio units submenu (Units)

The audio level scale is selectable.

Press any ▲ or ▼ button to select from the different audio level units:

- dBV
- dBu (default)

Output 3 submenu

Output 3 may be set to output audio through the left and/or right channels.

Press any ▲ or ▼ button to select the audio output from Output 3's phono jack:

- **Left and right channel** (default) — output audio from both left and right channels of Output 3.
- **Right only** — output audio from the right channel and disable the left channel, and disable Output 1 (RCA) and Output 2 (XLR).
- **Left only** — output audio from left channel only and disable the right channel.

Video Setup Menu

The following flowchart provides an overview of the Video Setup menu.

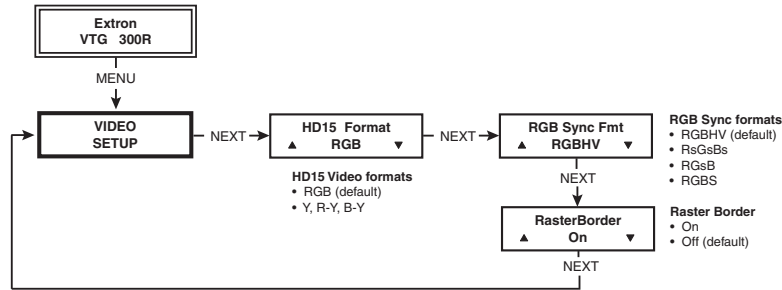

Figure 6. Video Setup menu

HD15 Video format submenu (HD15 Format)

There are two video formats that can be output from the 15-pin HD connector.

Press any ▲ or ▼ button to select from among the formats:

- RGB (default)
- Y, R-Y, B-Y

RGB Sync format submenu (RGB Sync Fmt)

The VTG offers a choice of four RGB sync formats. Press any ▲ or ▼ button to select from among the formats:

- RGBHV (default)
- RGSB
- RGsB
- RsGsBs

Raster border submenu (RasterBorder)

A white border may be placed around the active area of a video signal. Press any ▲ or ▼ button to enable (On) or disable (Off) the border:

- On
- Off (default)

Advanced Setup Menu

The following flowchart provides an overview of the Advanced Setup menu.

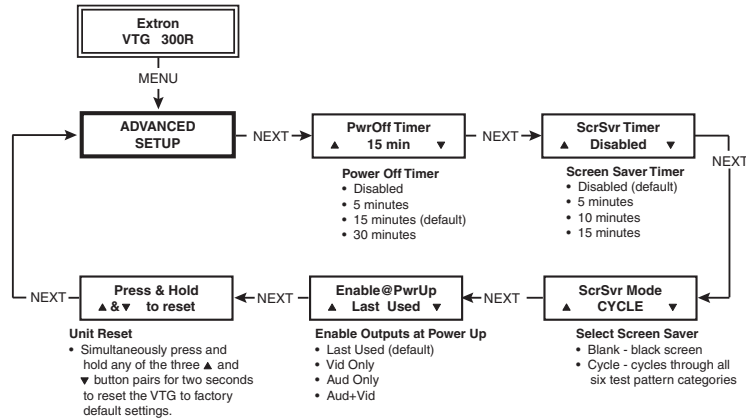

Figure 7. Advanced Setup Menu

Power off timer submenu (PwrOff Timer)

When enabled, this feature allows the VTG to be automatically powered off after a certain period of button inactivity has elapsed. This power off feature conserves battery power.

NOTE: When the VTG is powered by the external power supply, this power off feature is disabled.

Press any ▲ or ▼ button to select from among the power off timer options:

- Disable - disable this timer feature
- 5-minute power off time out
- 15-minute power off time out (default)
- 30-minute power off time out

Screen saver timer submenu (ScrSvr Timer)

This feature protects against CRT/plasma burn-in. When enabled, this feature allows the VTG to set the screen saver inactivity timer. This timer will activate the screen saver after the selected timer interval has elapsed without any button being pressed. See the Screen saver mode submenu (ScrSvr) description in this chapter for selecting a screen saver display.

Press any ▲ or ▼ button to select from among the screen saver timer options:

- Disable - disable this timer feature (default)
- 5-minute screen saver time out
- 10-minute screen saver time out
- 15-minute screen saver time out

Selecting any of the time outs will result in a modified default menu cycle, as shown in [figure 8](#). While timed out, pressing any front panel button will cancel (disable) the time out.

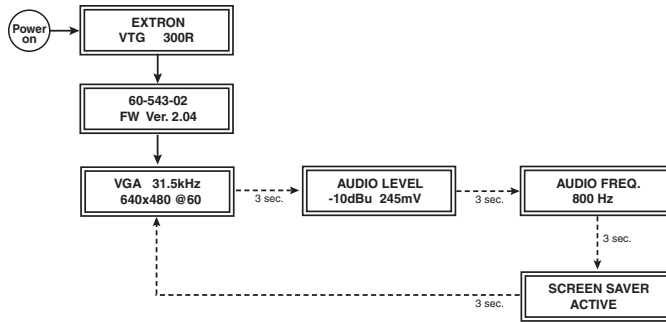

Figure 8. Screen Saver Default Menu Cycle

Screen saver mode submenu (ScrSvr Mode)

If the screen saver timer has been enabled (see the [Screen saver timer submenu](#)), the resulting screen saver display may be in one of two modes. The Blank mode will display a blacked out screen, and the Cycle mode will display all six categories of test patterns at 4 second intervals.

NOTE: Although the output screen will be blacked out when the Blank screen saver mode has been selected, the output sync will still remain active.

Press any ▲ or ▼ button to select from among the screen saver modes:

- **Blank** – displays a black screen
- **Cycle** – displays the six test pattern categories: crosshatch, H pattern, color bars, grayscale, alternating pixels/multiburst, and white field

Figure 8 shows the modified default menu cycle whenever the screen saver feature is activated. The additional **Screen Saver Active** menu will be displayed in the default menu cycle.

Enable at power up submenu (Enable@PwrUp)

This submenu only displays when the VTG is powered by batteries. When enabled, this feature allows the VTG to set the active audio and/or video output during power up. This is a power saving feature of the VTG. Press any ▲ or ▼ button to enable the selected outputs:

- **Last used** (default) – only the last used functions (audio or video) output is enabled during power up.
- **Video only (Vid)** – the video outputs are enabled and the audio outputs are disabled.
- **Audio only (Aud)** – the audio outputs are enabled and the video outputs are disabled.
- **Audio and video (Aud+Vid)** – both audio and video outputs are enabled, regardless of which outputs were last used.

NOTES:

- If an output is disabled at power up, it can be reactivated by pressing one of its function buttons.
- When the VTG is powered by the external power supply, both audio and video outputs are enabled regardless of the setting.

Backlight submenu (BackLight)

This submenu only displays when the VTG is powered by batteries. When set to off (default), this feature does not illuminate the backlight of the LCD. This is a power saving feature of the VTG to extend battery life. Press any ▲ or ▼ button to turn the backlight on. When set on, the backlight goes inactive (the backlight goes off, but the backlight status is still set on) after 2 seconds of button inactivity, but will light again when any button is pressed.

NOTE: When the VTG is powered by both the external power supply and batteries, the external power supply provides the power, not the batteries.

Unit Reset submenu (Press & Hold)

The VTG can be reset to factory default values. Any of the adjacent ▲ or ▼ button pairs (Level, Frequency, or Rate) will activate the reset.

Press and hold both ▲ or ▼ buttons simultaneously for two seconds to reset the VTG to its factory defaults.

- The message “Unit Reset to Factory Defs ” will be displayed.

Exit Menu

The flowchart in [figure 9](#) describes the Exit menu.

Pressing the **Next** button from this menu will return you to the default menu cycle.

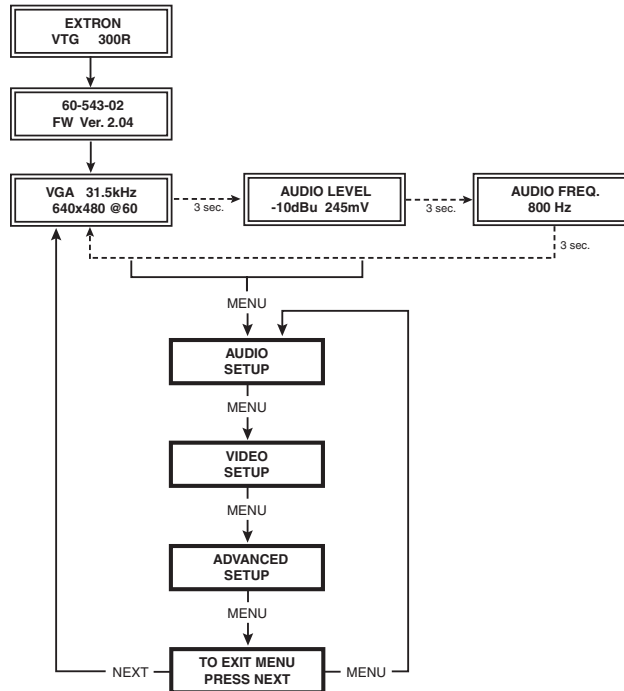

Figure 9. Exit Menu

Additional Functions

In addition to the main menu system, there are several other functions that are featured by the VTG. A low battery warning message and a button lock mode that locks out all front panel buttons, except the power button, are also featured.

Low Battery Mode

When the batteries in the VTG are low and the external power supply is not connected, the message “Warning: Battery Low!” flashes on the LCD for one second every 30 seconds. To end this cycle, the external power supply needs to be connected or the batteries need to be recharged or replaced (see [Installing the VTG 300 Batteries](#) on page 20).

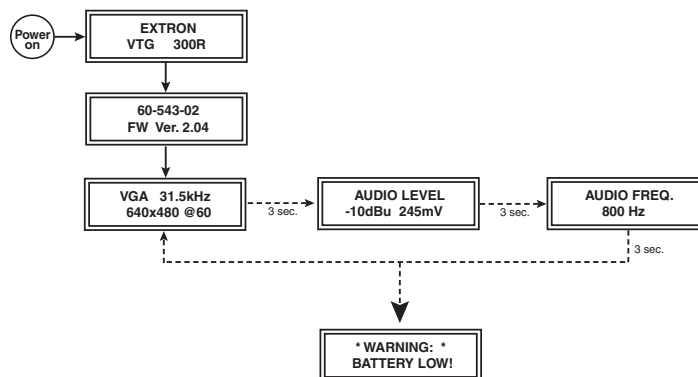

Figure 10. Low Battery Warning Mode

Button Lock Mode

To prevent accidental changes to settings, simultaneously press and hold the **Signal** and the **Test Patterns** buttons for two seconds to enable the VTG's Button Lock mode (see the [figure 11](#)). Button Lock mode locks all front panel buttons except Power. When Button Lock mode has been enabled, the message "Button Lock Enabled" is displayed for 2 seconds before the VTG returns to the default cycle.

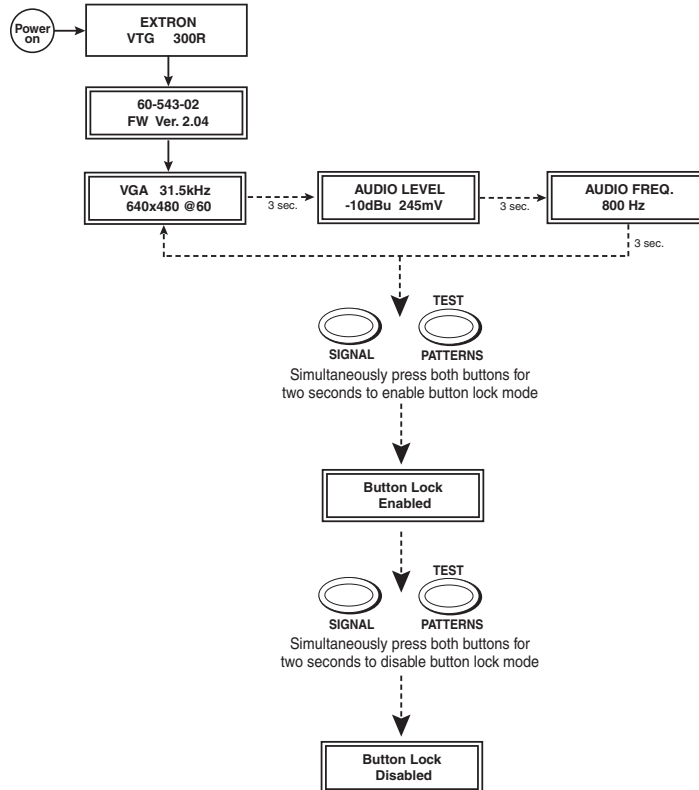

Figure 11. Button Lock Mode

NOTE: When the VTG is in Button Lock mode and powered off and then on again, the VTG will still remain in Button Lock mode until that mode is disabled.

To disable Button Lock mode, simultaneously press and hold the **Signal** and the **Test Patterns** buttons for two seconds. When Button Lock mode has been disabled, the message "Button Lock Disabled" is displayed for 2 seconds before the VTG returns to the default cycle.

Audio Testing Features

The VTG can output from among six different audio signal formats. The audio level can also be selected from a range of levels available for each audio format.

Depending on the audio signal format, the audio frequency may be selected from a range of values (see **Front Panel Features** on page 2 for button descriptions).

Selecting Audio Signals

The following table summarizes the six audio signal formats available through the VTG. Pressing the **Signal** button repeatedly will scroll through the signals and light the green LED indicators.

Audio Signal Format	Description
Pink Noise	Random noise that has constant energy per octave. Used in loudspeaker testing and calibration.
White Noise	Random noise that has an equal energy distribution across all frequencies between 20 Hz and 20 kHz.
Sine Wave	Used in detecting distortion. The frequency can be set from 20 Hz to 20 kHz (in 1/3 octave steps).
Square Wave	Used in amplitude and phase versus frequency measurements. The frequency can be set from 20 Hz to 5 kHz.
Polarity test	Proprietary waveform used in verifying the polarity of audio wiring.
Swept Sine Wave	Varies the frequency of a sine wave signal continuously from 20 Hz to 20 kHz. Used to detect driver defects and mechanical sources of distortion.

Setting the Audio Level

The audio level for each audio signal type is selected from a range of values using the ▲ or ▼ Level buttons. The following table lists the range of values.

Audio Signal Format	Audio Level Range (in 2 dBu increments)	Audio Level Range (in 2 dBV increments)
Pink Noise	-8 dBu to -56 dBu	-10 dBV to -58 dBV
White Noise	+6 dBu to -72 dBu	+4 dBV to -74 dBV
Sine Wave	+6 dBu to -72 dBu	+4 dBV to -74 dBV
Square Wave	+6 dBu to -72 dBu	+4 dBV to -74 dBV
Polarity test	-18 dBu to -72 dBu	-20 dBV to -74 dBV
Swept Sine Wave	+6 dBu to -72 dBu	+4 dBV to -74 dBV

NOTE: Displayed levels are for high impedance loads.
For 600-ohm loads, there is a -.7 dB (unbalanced) / -1.3 dB (balanced) difference between the displayed and actual levels.

Setting the Audio Frequency

The audio frequency for each audio signal type is selected from a range of values using the ▲ or ▼ Frequency buttons and observing the LCD. The following table lists the available frequencies.

Audio Signal Format	Audio Frequencies
Pink Noise	Not Applicable
White Noise	Not Applicable
Sine Wave	20 Hz, 25 Hz, 31.5 Hz, 40 Hz, 50 Hz, 63 Hz, 80 Hz, 100 Hz, 125 Hz, 160 Hz, 200 Hz, 250 Hz, 315 Hz, 400 Hz, 500 Hz, 630 Hz, 800 Hz, 1.0 kHz, 1.25 kHz, 1.6 kHz, 2.0 kHz, 2.5 kHz, 3.15 kHz, 4.0 kHz, 5.0 kHz, 6.3 kHz, 8.0 kHz, 10 kHz, 12.5 kHz, 16 kHz, 20 kHz
Square Wave	20 Hz, 25 Hz, 31.5 Hz, 40 Hz, 50 Hz, 63 Hz, 80 Hz, 100 Hz, 125 Hz, 160 Hz, 200 Hz, 250 Hz, 315 Hz, 400 Hz, 500 Hz, 630 Hz, 800 Hz, 1.0 kHz, 1.25 kHz, 1.6 kHz, 2.0 kHz, 2.5 kHz, 3.15 kHz, 4.0 kHz, 5.0 kHz
Polarity test	1 Hz
Swept Sine Wave	Sweep speed (in seconds): 150, 120, 90, 60, 30, 15, 1.5

NOTE: If the audio signal format is specified as swept sine wave, the default menu cycle will not indicate an audio frequency. A sweep speed will be displayed instead as shown in the following flowchart.

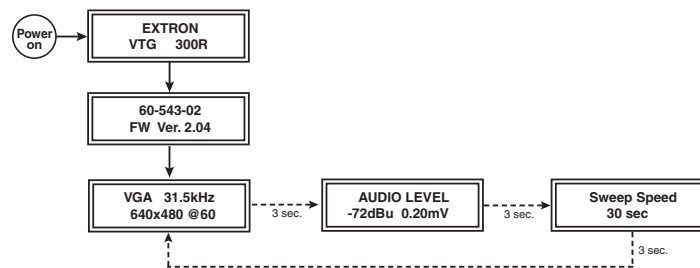

Figure 12. Sweep Speed Submenu

Video Testing Features

The VTG can output a total of 13 different test patterns by selecting from among six categories of test patterns (see [figure 13](#)):

- crosshatch (X-hatch)
- H pattern
- color bars (Col. Bars)
- grayscale
- alternating pixels/multiburst (Alt./Multi)
- white field (Wht. Field)

The output rate is selected by setting the signal range and the scan rate. See [Front Panel Features](#) on page 2 for descriptions of the **Test Patterns** button, the **Range** button, and the **Select** button.

NOTE: See the **Test Pattern Setup** menu to change the current Grayscale or White Field pattern.













Test Pattern Signal Range	Crosshatch		H Pattern	Color Bars			Grayscale		Alt/Multi		White Field		
	32 x 24	32 x 18		SMPTE	EBU	Split	32-Level Split	Ramp	Alternating Pixels	Multiburst	Full Field	80% Window	20% Window
PC													
VIDEO	✓		✓				✓	✓	✓		✓	✓	✓
HDTV	✓ 480p and 576p only	✓ Except 480p and 576p	✓	✓ NTSC only	✓ PAL only		✓	✓	✓		✓	✓	✓
16:9 HR		✓	✓						✓				✓

Figure 13. Six Categories of Test Patterns

Selecting a Video Test Pattern

Pressing the **Test Patterns** button will determine what category of test pattern to display. The signal range and/or the output rate also determine the actual test pattern. **Figure 14** provides a description of the available test patterns.











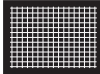

<p>Crosshatch - 32 x 24</p> 	<p>Static and Dynamic Convergence - This pattern can be used to set projector focus and geometry. For CRT projectors, this pattern is for examining and adjusting both static and dynamic convergence, so that the red, green, and blue video signals are aligned throughout the image. This pattern is also useful for evaluating some optical qualities of projector lenses, such as chromatic aberration.</p>	<p>Grayscale - 32-level split</p> 	<p>Video level tracking and video gain linearity - This pattern is used for setting and assessing grayscale tracking, and evaluating contrast linearity on displays. The pattern consists of two opposing rows of 32 stepped bars of gray between the lowest and highest levels.</p>
<p>Crosshatch - 32 x 18</p> 	<p>16:9 Static and Dynamic Convergence - This pattern can be used to set projector focus and geometry. For CRT projectors, this pattern is for examining and adjusting both static and dynamic convergence, so that the red, green, and blue video signals are aligned throughout the image. This pattern is also useful for evaluating some optical qualities of projector lenses, such as chromatic aberration.</p>	<p>Grayscale - ramp</p> 	<p>Pixel bit depth - This pattern is used to evaluate the performance of a display or video processor on the basis of its pixel bit depth capability. The pattern should appear to be smooth, with no contouring or stepping.</p>
<p>H Pattern - white on black</p> 	<p>Resolution/High Frequency Response - This pattern can be used to check display focus or video pulse response on PC, video, HDTV, and 16:9 HR equipment.</p>	<p>Alternating Pixels</p> 	<p>Monitor performance - This "one pixel on, one pixel off" pattern is used for assessing the performance of high resolution monitors and projectors, EMI testing for worst case radiation, and pixel clocking and pixel phasing adjustments on a digital display.</p>
<p>Color Bars</p> 	<p>8-color split bars - This pattern is used for testing all of the video color channels and setting video drive levels. It is also used to check low frequency crosstalk between the red, green, and blue color channels. Color levels are set to 100% (100 IRE).</p>	<p>Multiburst</p> 	<p>Bandwidth performance - This pattern, consisting of sine wave bursts of increasing frequency, tests bandwidth performance over the NTSC and PAL video channel.</p>
<p>SMPTE Color Bars</p> 	<p>SMPTE with PLUGE - For NTSC video equipment, the SMPTE color bars are used to set up tint and color, while the PLUGE video pattern is used for adjusting brightness and contrast. Color levels are set to 75% (75 IRE).</p>	<p>Flat Field (Full Field)</p> 	<p>White field uniformity - This pattern is used to evaluate white field uniformity.</p>
<p>EBU Color Bars</p> 	<p>EBU - The EBU color bars are primarily used to set up color for PAL video equipment.</p>	<p>White Field - 80% window</p> 	<p>Color balance adjustment - A window at 80% (80 IRE) video level, surrounded by black, is used in fine tuning the color balance (or grayscale) of a display with the aid of a color analyzer. The gain (or drive) setting is fine tuned for each of the red, green, and/or blue color adjustments.</p>
		<p>White Field - 20% window</p> 	<p>Color balance adjustment - A window at 20% (20 IRE) video level, surrounded by black, is used in fine tuning the color balance (or grayscale) of a display with the aid of a color analyzer. The bias (or offset) setting is fine tuned for each of the red, green, and/or blue color adjustments.</p>

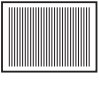
Figure 14. VTG 300/300R Test Patterns

Selecting a Signal Range

Press the **Range** button to select from either a computer output rate (PC), video output rate (NTSC, PAL, and so forth), HDTV output rate, or 16:9 HR output rate.

Setting the Scan Rate

The scan rate for a signal range is selected from a list of rates using the ▲ or ▼ Rate buttons and observing the LCD. The scan rate options are as follows:

<u>Output type</u>	<u>Rate</u>
PC VGA 31.50 kHz, 640x480 @ 60 Hz
 VGA 37.50 kHz, 640x480 @ 75 Hz
 SVGA 37.90 kHz, 800x600 @ 60 Hz
 SVGA 46.90 kHz, 800x600 @ 75 Hz
 XGA 48.40 kHz, 1024x768 @ 60 Hz
 XGA 56.40 kHz, 1024x768 @ 70 Hz
 XGA 60.00 kHz, 1024x768 @ 75 Hz
 SXGA 64.00 kHz, 1280x1024 @ 60 Hz
 SXGA 91.10 kHz, 1280x1024 @ 85 Hz
 SXGA+1 64.00 kHz, 1400x1050 @ 60 Hz
 SXGA+2 65.00 kHz, 1400x1050 @ 60 Hz
 UXGA 75.00 kHz, 1600x1200 @ 60 Hz
 UXGA 87.50 kHz, 1600x1200 @ 70 Hz
 UXGA 106.30 kHz, 1600x1200 @ 85 Hz
 LCoS 80.00 kHz, 1360x1024 @ 75 Hz
..... LCoS 65.20 kHz, 1365x1024 @ 60 Hz	
Video NTSC 15.70 kHz, @ 59.94/29.97 Hz
 NTSC 0 IRE 15.70 kHz, @ 59.94/29.97 Hz
 PAL - I 15.60 kHz, @ 50/25 Hz
 PAL - B, G, H 15.60 kHz, @ 50/25 Hz
 PAL - N 15.60 kHz, @ 50/25 Hz
HDTV 480p: 31.50 kHz, 720x480 @ 60 Hz
 576p: 31.25 kHz, 720x576 @ 50 Hz
 720p: 45.00 kHz, 1280x720 @ 60 Hz
 1080i: 33.75 kHz, 1920x1080 @ 60/30 Hz
 1080i: 28.12 kHz, 1920x1080 @ 50/25 Hz
 1080p: 67.50 kHz, 1920x1080 @ 60 Hz
 1080p: 56.20 kHz, 1920x1080 @ 50 Hz
 1080pSF: 27.00 kHz, 1920x1080 @ 24 Hz
16:9 HR 16:9 31.02 kHz, 848x480 @ 60 Hz
 16:9 31.80 kHz, 852x480 @ 60 Hz
 WXGA1 45.11 kHz, 1280x768 @ 56 Hz
 WXGA3 47.77 kHz, 1280x768 @ 60 Hz
 WXGA4* 49.70 kHz, 1280x800 @ 60 Hz
 WXGA5 47.70 kHz, 1360x765 @ 60 Hz
 WXGA6* 47.71 kHz, 1360x768 @ 60 HZ
 WXGA8* 47.71 kHz, 1366x768 @ 60 Hz

Output type		Rate
16:9 HR (cont.)	WSXGA*	55.94 kHz, 1440x900 @ 60Hz
	WSXGA+1*	64.67 kHz, 1680X1050 @ 60Hz
	WSXGA+2*	65.29 kHz, 1680X1050 @ 60Hz
	1080P PC	67.20 kHz, 1920x1080 @ 60Hz
	WUXGA1*	74.04 kHz, 1920x1200 @ 60 Hz
	WUXGA2	74.60 kHz, 1920x1200 @ 60 Hz

NOTE:

- For NTSC/PAL rates, the component video output is intended for signal verification and alignment, and should not be used as a reference.
- * Firmware 2.05 or higher includes these resolutions. Units with firmware 1.xx are not able to be upgraded to 2.xx firmware.

Installing the VTG 300 Batteries

Four AA batteries (rechargeable or alkaline) may power the VTG 300 and are easily installed. With the protective boot removed, use a flat blade screwdriver to loosen the captive screw and remove the rear battery pack cover. Replace the batteries while observing the correct polarity molded in the battery cradle as the batteries are installed. Reinstall the cover (see [figure 15](#)).

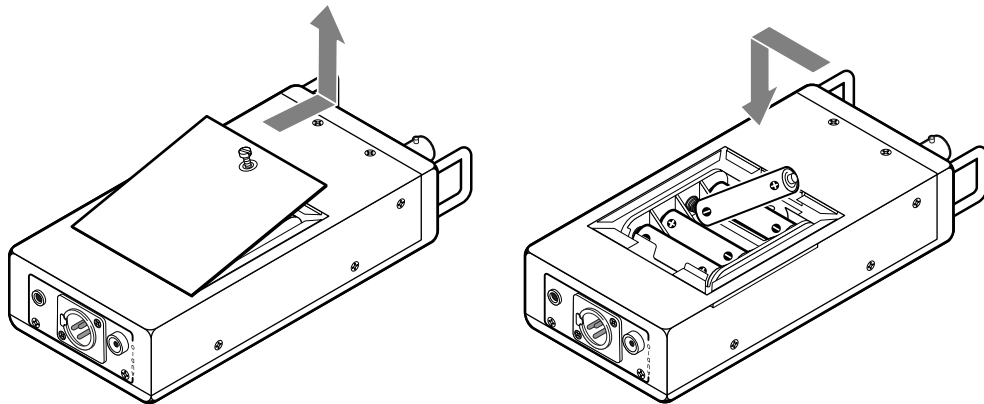

Figure 15. Battery Installation

Conserving the VTG 300 Battery Life

In order to conserve battery life, batteries should be removed from the VTG 300 if it will not be used for an extended period of time. For information specific to the VTG 300R charging system, see the following section [Recharging the VTG 300R](#).

Use these battery-saving features whenever possible to maximize the operational life of the VTG 300/300R batteries:

- Backlight mode (set to “**Off**”)
- Enable at power up (set to “**Last Used**”)
- Power off timer (set to as short an interval as possible)

Battery Operational Life Expectancy (VTG 300 only)	
Battery Type	Range (hours:minutes)
Alkaline	1:10 to 2:45
Rechargeable (NiMH)	1:20 to 3:10

NOTE: For best results, use high quality alkaline batteries or high current-capacity (2000 mA or greater) NiMH rechargeable batteries.

Recharging the VTG 300R

NOTE: Prior to using the VTG 300R for the first time, please be sure that the batteries are fully charged. The VTG 300R batteries are not covered under the Extron three year warranty.

A fully discharged VTG 300R may take up to eight hours to reach the fully charged state. The charging process will automatically end after the batteries are fully charged or after eight hours have elapsed, whichever occurs first.

Once fully charged, the VTG 300R may operate for up to five hours of normal use.

Although the VTG 300R may operate with the charger still actively powered and connected to the unit, the built-in batteries will have a longer life if the charger is used to fully charge the VTG 300R whenever the VTG 300R is powered off.

The amber charge status LED on the side of the VTG 300R will:

- Blink steadily when the unit is fully charged.
- Light steadily while the unit is being charged.
- Not light if there is no input power to the charging circuit.

NOTES:

- During the recharging process, a faint buzzing sound may be heard from the VTG 300R, the power supply, or both. This is a normal occurrence and should be no cause for concern.
- The VTG 300R charging circuit features short circuit protection. If a short occurs, a heat sensitive thermal fuse will cause an open circuit and prevent damage to the charging system.
- When the batteries become fully charged or the charging time exceeds eight hours, the charging process will automatically end.

WARNING: During the recharging process, the VTG 300R case should never feel so hot to the touch such that it cannot be held. Should this unlikely event occur, please discontinue the recharging process and contact your Extron representative.

Installing the Protective Boot

The included protective rubber boot protects the VTG from abuse and shock while it is in use. The boot may also be reversed to protect the front panel when not in use (see [figure 16](#)).

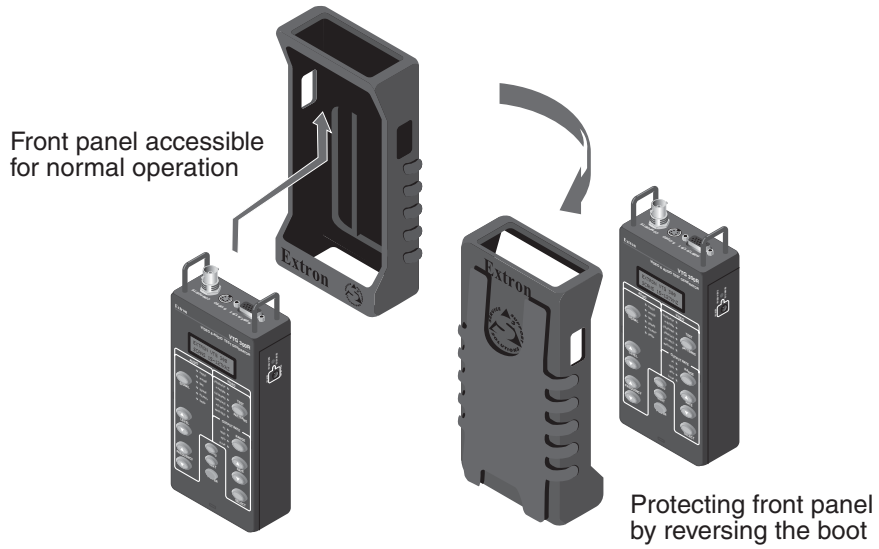

Figure 16. Boot Installation

Reference Information

This section provides information on:

- **Specifications**
- **Included Parts**

Specifications

Video signal characteristics

Dot clock.....	108 MHz (max.)
Pixel clock accuracy	100 ppm
Horizontal frequency	15 kHz to 127 kHz
Vertical frequency.....	30 Hz to 85 Hz
Rise/fall time	
Composite and S-video	140 ns
All other signal types	<4 ns

Video output

Number/signal type	1 RGBHV, RGBS, RGsB, RsGsBs, component video, S-video, composite video
Connectors	(1) 15-pin HD female (RGB/component) (1) 4-pin mini DIN female (S-video) 1 BNC female (composite video)
Nominal level	1 Vp-p for Y of component video and S-video, and for composite video 0.7 Vp-p for RGB and for R-Y and B-Y of component video 0.286 Vp-p (burst) for C of S-video
Minimum/maximum levels.....	0.0 V to 1.0 Vp-p
Impedance	75 ohms
Resolutions.....	Computer (VGA–WUXGA), video (NTSC, PAL), HDTV, and 16:9 high resolutions
Return loss	-30 dB @ 5 MHz
DC offset	±5 mV for RGB and component video, ±30 mV for S-video and composite video

Sync

Output type	RGBHV, RGBS, RGsB, RsGsBs (for RGB signals) Tri-level on Y, R-Y, B-Y channels (component video 720p, 1080i, 1080p) Bi-level on Y channel (for all other component video rates)
Standards.....	NTSC 3.58, NTSC 4.43, PAL, SMPTE 170M, SMPTE 274M, SMPTE 293M, SMPTE 295M, SMPTE 296M
Output level	0.3 Vp-p for component video (bi-level sync) 0.6 Vp-p for component video (tri-level sync) TTL: 5.0 Vp-p, unterminated for RGBHV, RGBS
Output impedance	60 ohms
Max. rise/fall time.....	5 ns (TTL sync)
Polarity.....	Positive or negative (signal dependent)

Audio

THD + Noise	0.06% @ 1 kHz at nominal level
Flatness	±0.1 dB
Accuracy	±0.7 dB

Audio output

Number/signal type	1 mono, balanced 2 mono, unbalanced
Connectors	(1) 3.5 mm mini stereo jack (unbalanced mono left and right, tip-ring-sleeve) 1 female RCA jack (unbalanced, tip-ring) 1 male 3-pin XLR (balanced)

NOTE: The XLR output is immune to phantom power.

Impedance	50 ohms unbalanced, 100 ohms balanced
Waveforms	Pink noise, white noise, sine wave (fixed/swept), square wave, polarity test
Level ranges	Pink noise: -56 dBu to -8 dBu (-58 dBV to -10 dBV) (1.25 mV to 316 mVrms) Polarity test: -72 dBu to -18 dBu (-74 dBV to -20 dBV) (0.20 mV to 100 mVrms) All other signal types: -72 dBu to +6 dBu (-74 dBV to +4 dBV) (0.20 mV to 1.6 Vrms)
Maximum level (Hi-Z)	>+6 dBu, balanced or unbalanced at 1% THD+N
Maximum level (600 ohm)	>+5.30 dBu, balanced or unbalanced at 1% THD+N
Crest factor (pink noise)	3.06 (9.73 dB)
Crest factor (white noise)	1.73 (4.75 dB)

NOTE: 0 dBu = 0.775 V, 0 dBV = 1 V, 0 dBV ≈ 2 dBu.

General

Power	Supplied by internal batteries or an external power supply
External power supply	100 VAC to 240 VAC, 50-60 Hz, external; to 12 VDC, 1 A, regulated
Power input requirements	12 VDC, 1 A
Batteries	
VTG 300	
Number/type	4 AA batteries (1.5 V alkaline or 1.2 V rechargeable)
Operating time (h:mm)	Alkaline batteries: 1:10 to 2:45, continuous use Rechargeable NiMH batteries: 1:20 to 3:10, continuous use
VTG 300R	
Number/type	1 rechargeable battery pack (4.8 V NiMH, 4000 mAh)
Operating time (h:mm)	5:10 (continuous use)
Recharging time	8 hours
Temperature/humidity	Storage: -40 to +158 °F (-40 to +70 °C) / 10% to 90%, noncondensing Operating: +32 to +122 °F (0 to +50 °C) / 10% to 90%, noncondensing
Mounting	No
Enclosure type	Metal
Enclosure dimensions	6.9" H x 3.4" W x 1.5" D (17.5 cm H x 8.6 cm W x 3.8 cm D) (Excluding the rubber boot, connectors, and handles.) 8.3" H x 3.9" W x 2.1" D (21.0 cm H x 9.9 cm W x 5.4 cm D) (Including the rubber boot, connectors, and handles.)
Product weight	1.2 lbs (0.5 kg)
Shipping weight	4 lbs (2 kg)
Vibration	ISTA 1A in carton (International Safe Transit Association)

Regulatory compliance

- Safety VTG 300 only: CUL, UL
- EMI/EMC CE, C-tick, FCC Class A, ICES, VCCI
- MTBF 30,000 hours
- Warranty
 - Product..... 3 years parts and labor, excluding the VTG 300R's rechargeable battery pack
 - VTG 300R battery pack..... 90 days

NOTE: All nominal levels are at $\pm 10\%$

NOTE: Specifications are subject to change without notice.

Included Parts

These items are included in each order for a VTG300/300R.

Included Parts	Part Numbers
VTG 300	60-543-01
VTG 300R	60-543-02
Rubber boot (blue)	70-370-01
VTG 300/300R Setup Guide	
Label	
External power supply (VTG 300 only)	70-055-03

Extron Warranty

Extron Electronics warrants this product against defects in materials and workmanship for a period of three years from the date of purchase. In the event of malfunction during the warranty period attributable directly to faulty workmanship and/or materials, Extron Electronics will, at its option, repair or replace said products or components, to whatever extent it shall deem necessary to restore said product to proper operating condition, provided that it is returned within the warranty period, with proof of purchase and description of malfunction to:

USA, Canada, South America, and Central America:

Extron Electronics
1001 East Ball Road
Anaheim, CA 92805
U.S.A.

Japan:

Extron Electronics, Japan
Kyodo Building, 16 Ichibancho
Chiyoda-ku, Tokyo 102-0082
Japan

Europe, Africa, and the Middle East:

Extron Europe
Hanzeboulevard 10
3825 PH Amersfoort
The Netherlands

China:

Extron China
686 Ronghua Road
Songjiang District
Shanghai 201611
China

Asia:

Extron Asia
135 Joo Seng Road, #04-01
PM Industrial Bldg.
Singapore 368363
Singapore

Middle East:

Extron Middle East
Dubai Airport Free Zone
F12, PO Box 293666
United Arab Emirates, Dubai

This Limited Warranty does not apply if the fault has been caused by misuse, improper handling care, electrical or mechanical abuse, abnormal operating conditions, or modifications were made to the product that were not authorized by Extron.

NOTE: If a product is defective, please call Extron and ask for an Application Engineer to receive an RA (Return Authorization) number. This will begin the repair process.

USA: (714) 491-1500

Asia: 65.6383.4400

Europe: 31.33.453.4040

Japan: 81.3.3511.7655

Units must be returned insured, with shipping charges prepaid. If not insured, you assume the risk of loss or damage during shipment. Returned units must include the serial number and a description of the problem, as well as the name of the person to contact in case there are any questions.

Extron Electronics makes no further warranties either expressed or implied with respect to the product and its quality, performance, merchantability, or fitness for any particular use. In no event will Extron Electronics be liable for direct, indirect, or consequential damages resulting from any defect in this product even if Extron Electronics has been advised of such damage.

Please note that laws vary from state to state and country to country, and that some provisions of this warranty may not apply to you.

Extron Headquarters +1.800.633.9876 (Inside USA/Canada Only) Extron USA - West +1.714.491.1500 Extron USA - East +1.919.863.1794 +1.714.491.1517 FAX	Extron Europe +800.3987.6673 (Inside Europe Only) +31.33.453.4040 +31.33.453.4050 FAX	Extron Asia +800.7339.8766 (Inside Asia Only) +65.6383.4400 +65.6383.4664 FAX	Extron Japan +81.3.3511.7655 +81.3.3511.7656 FAX	Extron China +4000.398766 (Inside China Only) +86.21.3760.1568 +86.21.3760.1566 FAX	Extron Middle East +971.4.2991800 +971.4.2991880 FAX	Extron Korea +82.2.3444.1571 +82.2.3444.1575 FAX	Extron India 1800.3070.3777 (Inside India Only) +91-80-3055.3777 +91 80 3055 3737 FAX
---	---	---	---	---	---	---	---