

IMPORTANT:
Go to www.extron.com for the complete user guide, installation instructions, and specifications before connecting the product to the power source.

The Extron IPCP Pro Q xi and xi Series IP Link® Pro Control Processors integrate Ethernet connection into AV systems to allow users to remotely control, monitor, and troubleshoot AV equipment, including display devices and switchers. All models include an embedded web server. Depending on the model, an IPCP control processor can include multiple bidirectional serial ports, relays, IR/serial ports, digital I/O, flex I/O, switched 12 VDC power output ports, a volume control port, or contact input ports for use in applications that require control and monitoring of multiple devices within a large-scale AV system.

All models except the IPCP Pro S1 xi and the IPCP Pro FOX3 Matrix Q xi Control Card include an Extron eBUS port, which allows a variety of eBUS devices to be connected to a single control processor. eBUS devices include an array of button panels as well as power and signal hubs. eBUS devices are automatically recognized by the control processor and can be added or removed at any time.

In this guide these products are referred to as the “IPCP,” “IPCP Pro Q xi,” “IPCP Pro xi,” or “control processor.” The xi models feature LAN ports. Q xi models feature both LAN and AV LAN ports. AV LAN ports provide a secure, dedicated network for the connection and isolation of AV devices.

This guide provides instructions for an experienced installer to install a control processor and to create a basic configuration.



Use Extron Toolbelt software to discover and manage the IPCP Pro control processor and other Extron control products. Configure the control processor using Extron Global Configurator® software running in Global Configurator Professional (GC Professional) or Global Configurator Plus (GC Plus) mode, or program the control processor using Extron Global Scriptor® (GS). The IPCP integrates seamlessly with Extron GlobalViewer® Enterprise (GVE) software and Extron Control apps for remote control applications. These control processors support multiple TouchLink® Pro touchpanel interfaces, Network Button Panels (NBPs), and IPL EXP expansion interfaces over a standard Ethernet network. Global Configurator and other useful software applications are available at www.extron.com.

Setup Checklist: How to Proceed With Installation

Get Ready

- Familiarize yourself with the features of the control processor (see [Front Panel Features — Models Without AV LAN](#) on page 4, [Front Panel Features — Models With AV LAN](#) on page 5, [Rear Panel Features — Models Without AV LAN](#) on page 6, and [Rear Panel Features — Models With AV LAN](#) on page 7) and of any TouchLink Pro touchpanels or button panels that will be part of the system.
- Download and install the latest version of the following:
 - **Toolbelt software** — for discovering the control processor and other control products on the network, for managing core settings, and for upgrading firmware when needed.
 - **Global Configurator (GC) software** — for configuring the control system
 - **Global Scriptor software** — for programming the control processor (as an alternative to GC)
 - **PCS Product Configuration Software** version 4.5 or higher — for setting the IP address for any IPCP Pro Q xi model with AV LAN ports if the ports are currently set to the default IP addresses
 - **GUI Designer software** — for designing layouts for Extron TouchLink Pro touchpanels and third-party touch interfaces
 - **IP Link Pro device drivers** — for use with GC, to make control of other AV devices possible
 - **IR Learner Pro software** — for use with models that have IR receiver ports. Use this to create your own IR drivers using the remote control of an AV device, if drivers are not already available from Extron

All are available from www.extron.com (see [Locating Software, Firmware, and Driver Files on the Extron Website](#) on page 15).

- Obtain network information for the unit from the network administrator. You also need the following details for each Extron Pro series Ethernet-enabled device:
 - DHCP setting (on or off)
 - Device (IPCP Pro, TouchLink Pro, IPL Pro, NBP) LAN IP address
 - AV LAN IP address (for models with AV LAN)
 - Subnet mask
 - Gateway IP address
 - Username
 - Passwords

IPCP Pro Q xi and xi Series • Setup Guide (Continued)

NOTE: If DHCP is on, you do not need the IP addresses and subnet mask.

- Write down the MAC address of each network interface on each IP Link Pro device to be used.
- Obtain model names and setup information for devices the IPCP will control.
- Each control processor comes with a factory-installed Secure Sockets Layer (SSL) security certificate. If you intend to install a different SSL certificate, contact your IT department to obtain the certificate or for instructions on how to obtain one. See “Secure Sockets Layer (SSL) Certificates” in the *IPCP Pro Q xi and xi Series User Guide* for requirements and guidelines regarding SSL certificates. IEEE 802.1X authentication is also supported once enabled (see “IEEE 802.1X Certificates” in the *IPCP Pro Q xi and xi Series User Guide* for details).

Mount and Cable All Devices

- Insert the IPCP Pro FOX3 Matrix Q xi card into a FOX3 matrix switcher and fasten it to the chassis, or mount a rack-mountable unit to a rack or furniture (see [Mounting](#) on the next page).
- Cable devices to the control processor (see [Cabling and Features](#) on page 8).
- Connect power cords and power on all the devices.

Set Up the Control Processor, Touchpanels, and Network Button Panels for Network Communication

- Connect the PC that you will use for setup, the LAN (or AV LAN) port of the control processor, and the touchpanels or network button panels to the same Ethernet network. For control processor LAN and AV LAN connections, see [Control, Bidirectional – LAN and AV LAN \(Ethernet\)](#) on page 9.
- Start Toolbelt and use it to set the IP address, subnet, gateway IP address, DHCP status, and related settings. See the flowchart in [Network Communication Setup](#) on the next page.

NOTES:

- When setting up DHCP during network configuration or if using a host name instead of an IP address, the user must enter a qualified host name (*Username.HostName.Domain*). For example: `somename.extron.com`.
- A dedicated AV LAN safeguards AV systems from outside intrusion or interference by separating device control and other network traffic from a corporate or campus network. To ensure that the control processor LAN and AV LAN connections (ports) are connected to separate networks, the LAN and AV LAN IP address schemes must be on different subnetworks.

Configure or Program the Control Processor, Touchpanels, and Network Button Panels

The most basic steps are outlined below in the recommended order.

NOTE: See the *Toolbelt Help File*, *Global Configurator Help File*, *Global Scripter Help File*, and *GUI Designer Help File* as needed for step-by-step instructions and detailed information. The help file for GC includes an introduction to the software and how to start a project and configuration.

- If TouchLink Pro or third party touchpanels are part of the system, start and use GUI Designer to **design, save, and build the graphical user interface (GUI) layout** for the touchpanels.

NOTE: To redeem (activate) a LinkLicense®, go to www.extron.com//lredeem and follow the online instructions.

- **Using GC, create a new GC Professional or GC Plus project and configure the control processor and other IP Link Pro devices.** The configuration tells the control processor:
 - How its ports function
 - How to control other products
 - Which touchpanels to interact with
 - What to monitor
 - When to do things
 - Whom to notify, how, and under what circumstances
- Configure ports on the control processor:
 - Select device drivers and link them to each serial, IR/serial, or Ethernet port.
 - Select settings (serial protocol, relay behavior, digital I/O or flex I/O settings) as needed.
- Add eBUS devices and set them up:
 - Ensure that the hardware address set on each device is distinct and matches the address used in the configuration.
 - Assign button functions as desired.
- Add Network Button Panels (NBPs) and set them up. Assign button functions as desired.
- Add IPL EXP expansion interfaces and set them up.
- Set up monitors, schedules, macros, and local variables.

- Add touchpanels and set them up:
 - Add the GUI configuration for each touchpanel to the GC project using Global Configurator.
 - Assign any appropriate functions, monitors, or schedules to the touchpanels and their buttons.
- **If not using GC Professional or GC Plus, use Global Scripter** to program the control system as desired.
 - Program ports on the control processor:
 - Program each serial, IR/serial, or Ethernet port.
 - Program relay behavior, digital I/O, and flex I/O settings as needed.
 - Add eBUS devices and set them up:
 - Ensure that the hardware address (eBUS ID) set on each device is distinct and matches the address programmed for it in the IPCP.
 - Program button functions as desired.
 - Add Network Button Panels and set them up. Program button functions as desired.
 - Add IPL EXP expansion interfaces and set them up.
 - Add touchpanels and set them up:
 - Upload the GUI configuration for the touchpanels to the project.
 - Program functions, monitors, or schedules to the touchpanels and their buttons.
- Save the GC or GS project.
- Build and upload the system configuration to the control processor and other system devices.

Test and Troubleshoot

- Test the system (see the *IPCP Pro Q xi and xi Series User Guide* for an outline of the system testing procedure).
- Make adjustments to wiring or configuration as needed.

Network Communication Setup

Network setup is essential prior to configuration. Use the flowchart in figure 1 at right as a guide to setting up the control processor for network use.

NOTE: If using 802.1X security, see the *Extron 802.1X Technology Reference Guide* and the *Toolbelt Help* file for additional details on system setup.

Mounting

Securely mount the control processor and other devices and attach cables using the wiring section (see **Cabling and Features** on page 8) as a wiring guide.

Rack and Furniture Mounting

Optional 1U rack shelves and furniture mounting bracket kits are available for use with the control processor. Read the instructions and UL guidelines that come with the rack shelf or mounting kit for installation procedures. See the product-specific page at www.extron.com for a list of compatible accessories for mounting your control processor.

Matrix Switcher Mounting

The IPCP Pro FOX3 Matrix Q xi control board mounts within the chassis of an Extron FOX3 matrix switcher using the captive panel screws (see **figure 3** on page 5). See the “Maintenance and Modifications” sections of the *FOX3 Matrix Series User Guide* or *FOX3 Matrix Series Setup Guide* (available at www.extron.com) for mounting instructions.

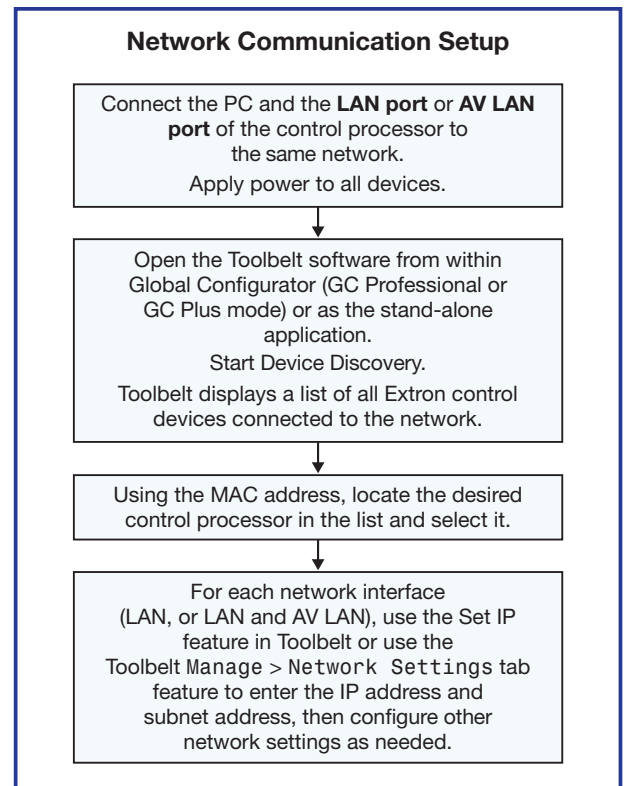

Figure 1. Network Setup

IPCP Pro Q xi and xi Series • Setup Guide (Continued)

Panels and Locations of Features

Location and quantity of LEDs and corresponding connectors vary by model, but the functions and port wiring are identical across models for each port type.

Front Panel Features – Models Without AV LAN

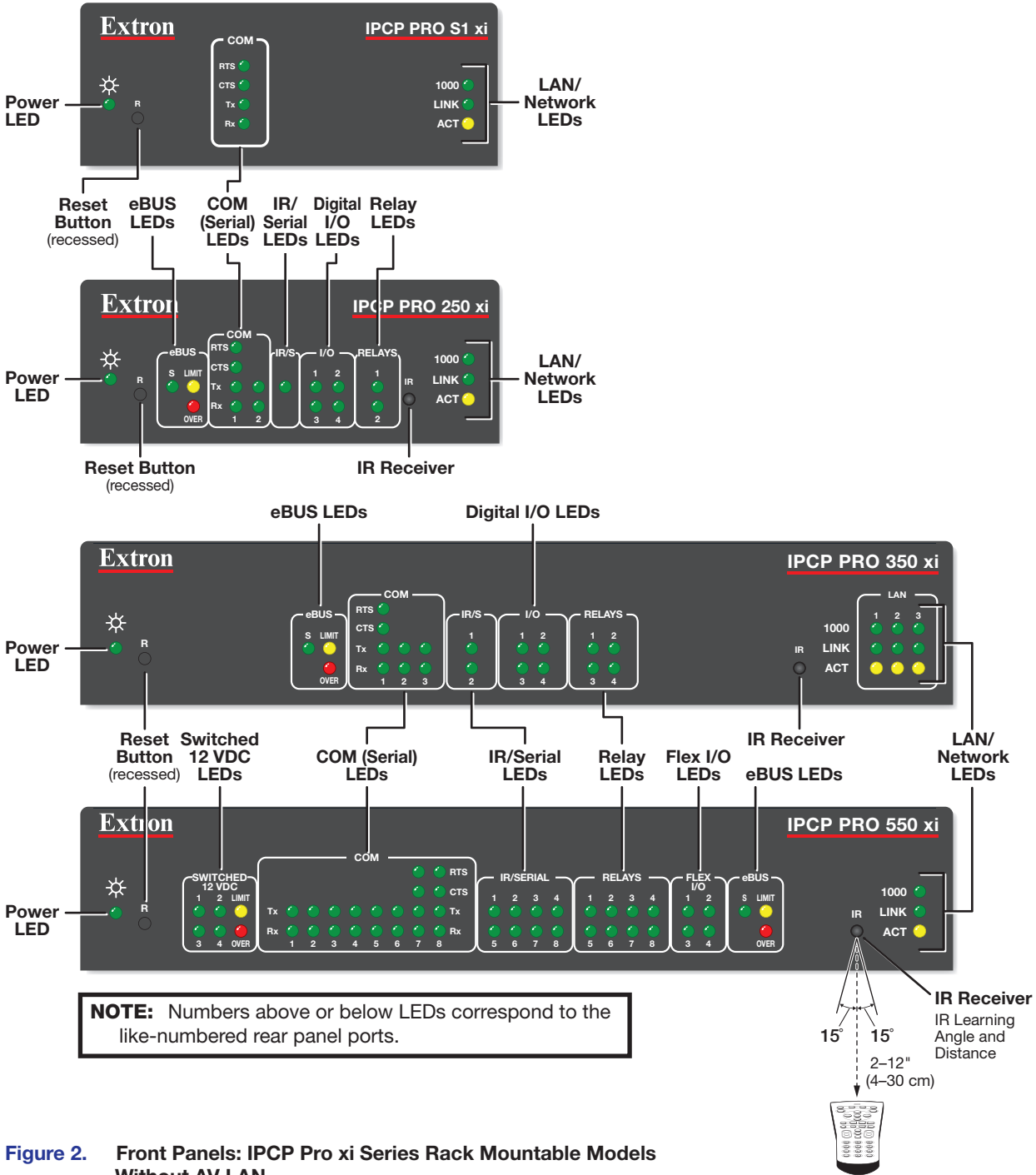

Figure 2. Front Panels: IPCP Pro xi Series Rack Mountable Models Without AV LAN

NOTE: For full reset mode information, see the *IPCP Pro Q xi and xi Series User Guide*.

Front Panel Features – Models With AV LAN

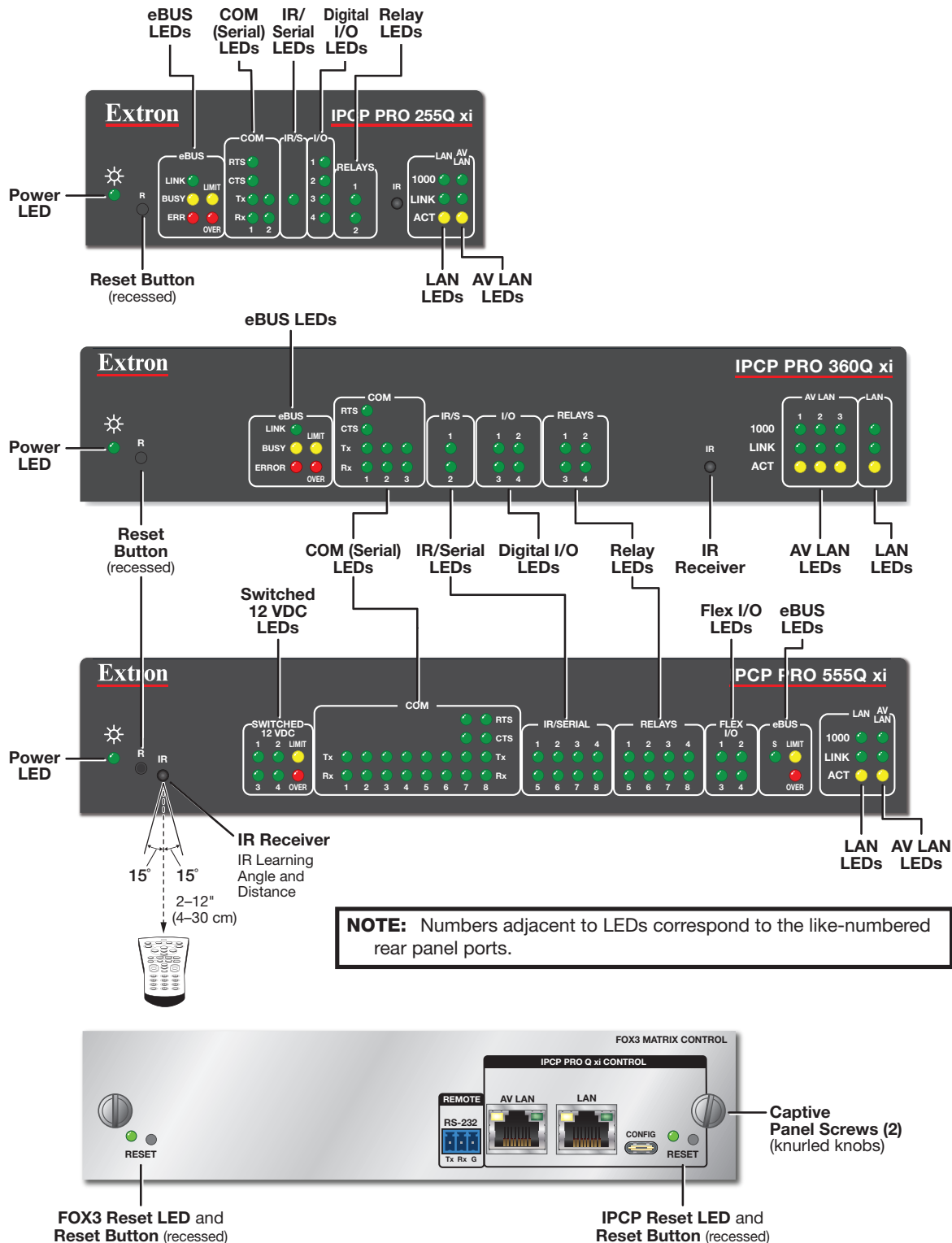

Figure 3. Front Panels: IPCP Pro Q xi Series Rack Mountable Models and IPCP Pro FOX3 Matrix Q xi Panel

NOTES:

- For the IPCP Pro FOX3 Matrix Q xi panel, also see **figure 5** in the “Rear Panel Features” section.
- See the *FOX3 Matrix Series User Guide*, available at www.extron.com, for information on the matrix switcher reset modes.
- See **Reset Modes: a Brief Summary** on page 14 for details on the IPCP reset modes.

IPCP Pro Q xi and xi Series • Setup Guide (Continued)

Rear Panel Features – Models Without AV LAN

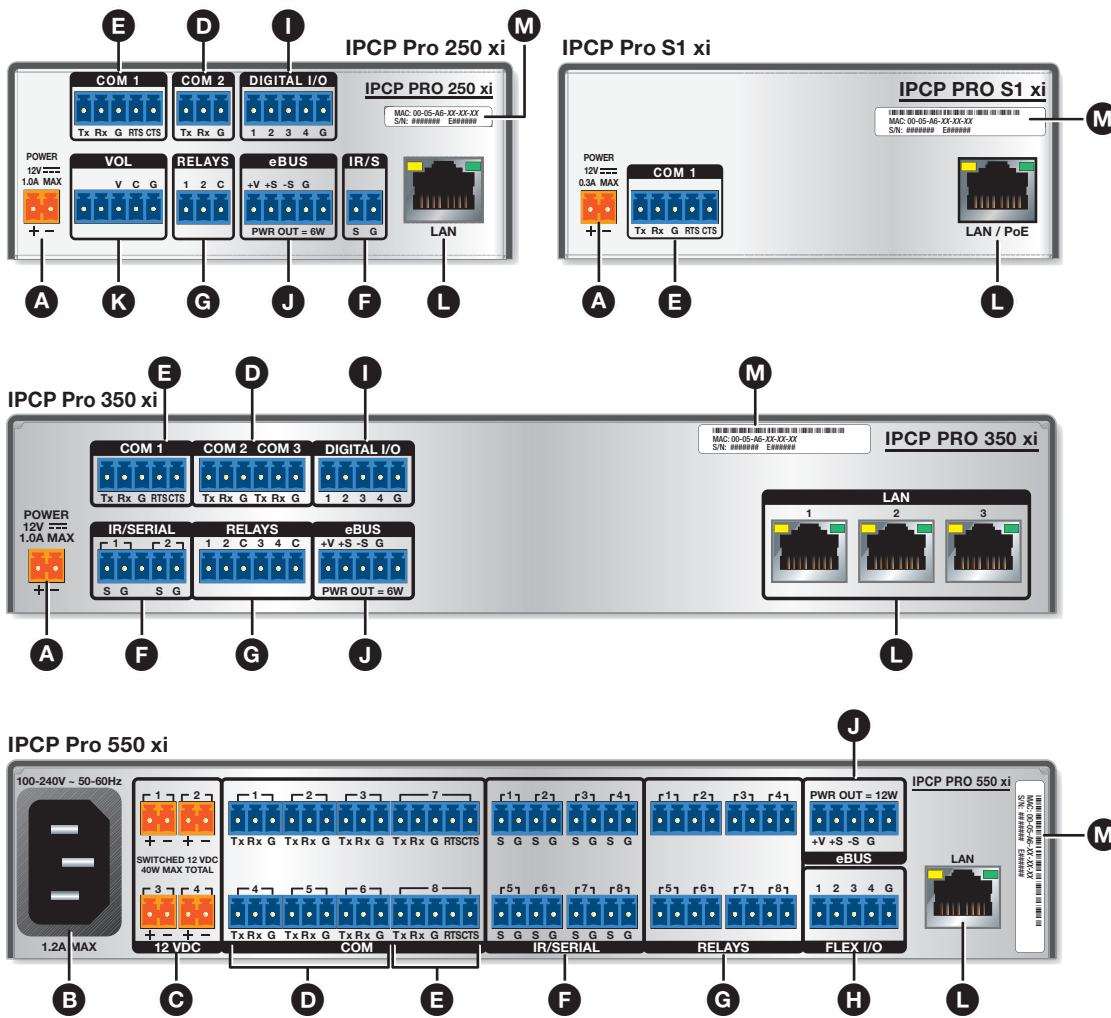

Figure 4. Rear Panels: IPCP Pro xi Control Processors Without AV LAN

- | | |
|---|---|
| <ul style="list-style-type: none"> A Power input connector (external power supply) B Power input connector (internal power supply) C Switched 12 VDC power output ports D 3-pole COM ports (RS-232-only) E 5-pole COM ports (RS-232/RS-422/RS-485) F IR/serial output ports G Relay ports | <ul style="list-style-type: none"> H Flex I/O ports (digital input/output or analog input) I Digital I/O ports (digital input/output) J eBUS ports K Volume control port L LAN connectors and LEDs (Ethernet) M MAC address label |
|---|---|

Rear Panel Features – Models With AV LAN

This section shows rear panels of some representative models with AV LAN.

IPCP Pro 255Q xi

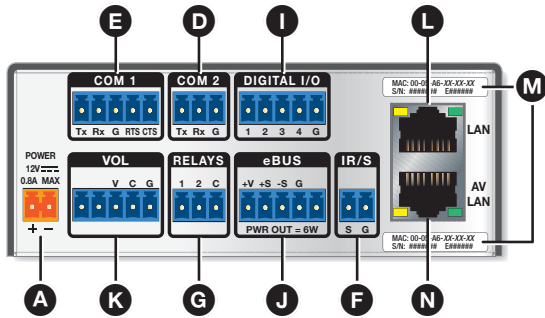

IPCP Pro 360Q xi

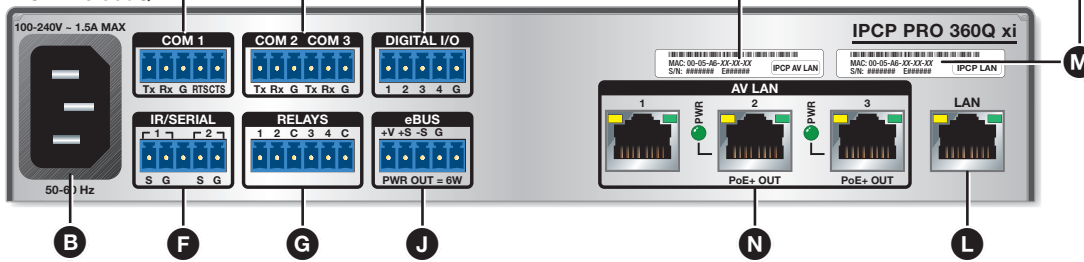

IPCP Pro 555Q xi

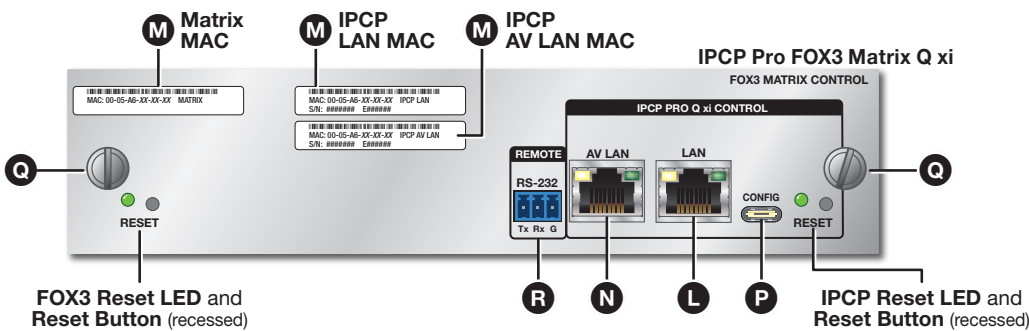
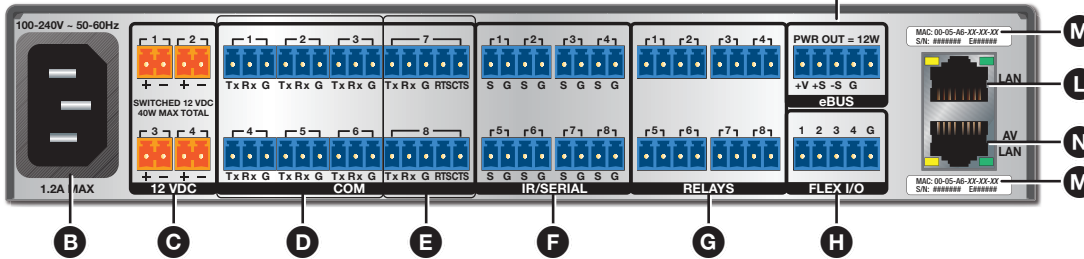

Figure 5. Rear Panels: IPCP Pro Q xi Control Processors and IPCP Pro FOX3 Matrix Q xi Panel

- A** Power input connector (external power supply)
- B** Power input connector (internal power supply)
- C** Switched 12 VDC power output ports
- D** 3-pole COM ports (RS-232-only)
- E** 5-pole COM ports (RS-232/RS-422/RS-485)
- F** IR/serial output ports
- G** Relay ports
- H** Flex I/O ports (digital input/output or analog input)
- I** Digital I/O ports (digital input/output)
- J** eBUS ports
- K** Volume control port
- L** LAN connectors and LEDs (Ethernet)
- M** MAC address labels
- N** AV LAN connector and LEDs (Ethernet), some with PoE+ and PoE LEDs
- P** USB C configuration port — For future use
- Q** Captive panel (mounting) screws (2)
- R** Remote RS-232 port — For direct SIS control of the matrix switcher (see the user guide for the FOX3 matrix switcher for details.)

IPCP Pro Q xi and xi Series • Setup Guide (Continued)

Cabling and Features

Attach cables using the following wiring diagrams as a guide. Full details are available in the *IPCP Pro Q xi and xi Series User Guide*.

ATTENTION:

- Installation and service must be performed by experienced personnel.
- L'installation et l'entretien doivent être effectués par du personnel expérimenté.

NOTE: The IPCP Pro FOX3 Matrix Q xi card is powered directly by a FOX3 matrix switcher.

Power Input – External

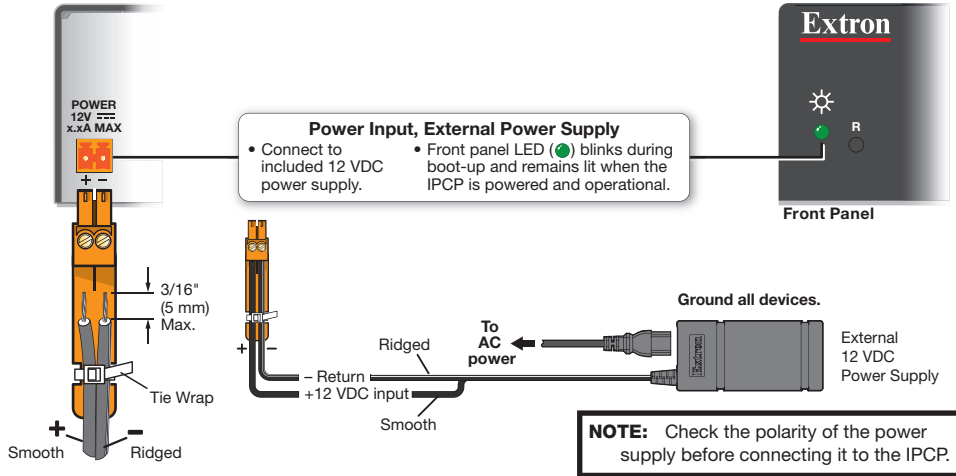

ATTENTION:

- Always use a power supply supplied or specified by Extron. Use of an unauthorized power supply voids all regulatory compliance certification and may cause damage to the supply and the unit.
- Utilisez toujours une source d'alimentation fournie ou recommandée par Extron. L'utilisation d'une source d'alimentation non autorisée annule toute certification de conformité réglementaire et peut endommager la source d'alimentation et l'unité.

Power Input – Internal

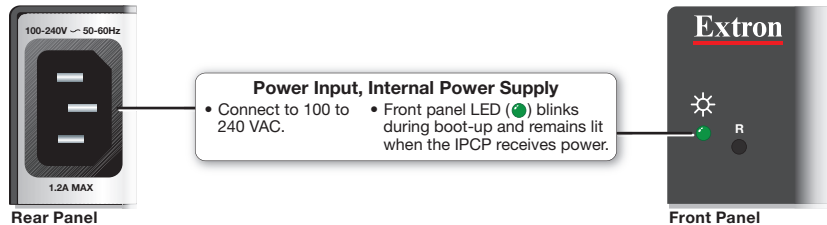

Power Output – Switched 12 VDC Power Output

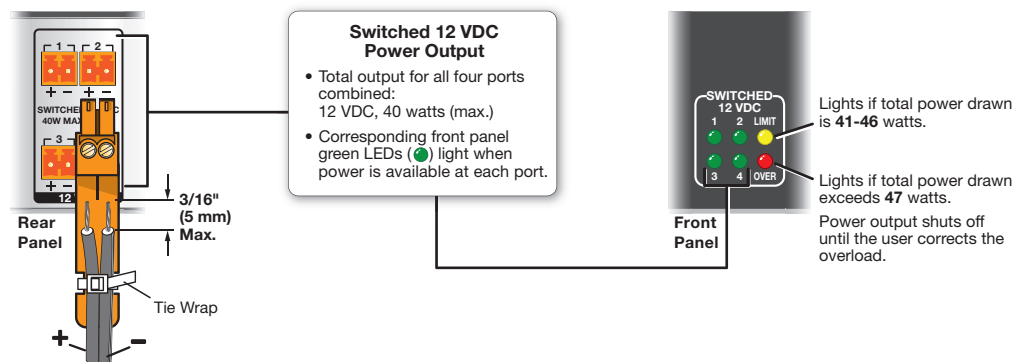

Power Output – PoE+

The IPCP Pro 360Q xi can output PoE+ on AV LAN ports 2 and 3. For details, see the [PoE+ output](#) information on page 11.

Control, Bidirectional – Serial (COM)

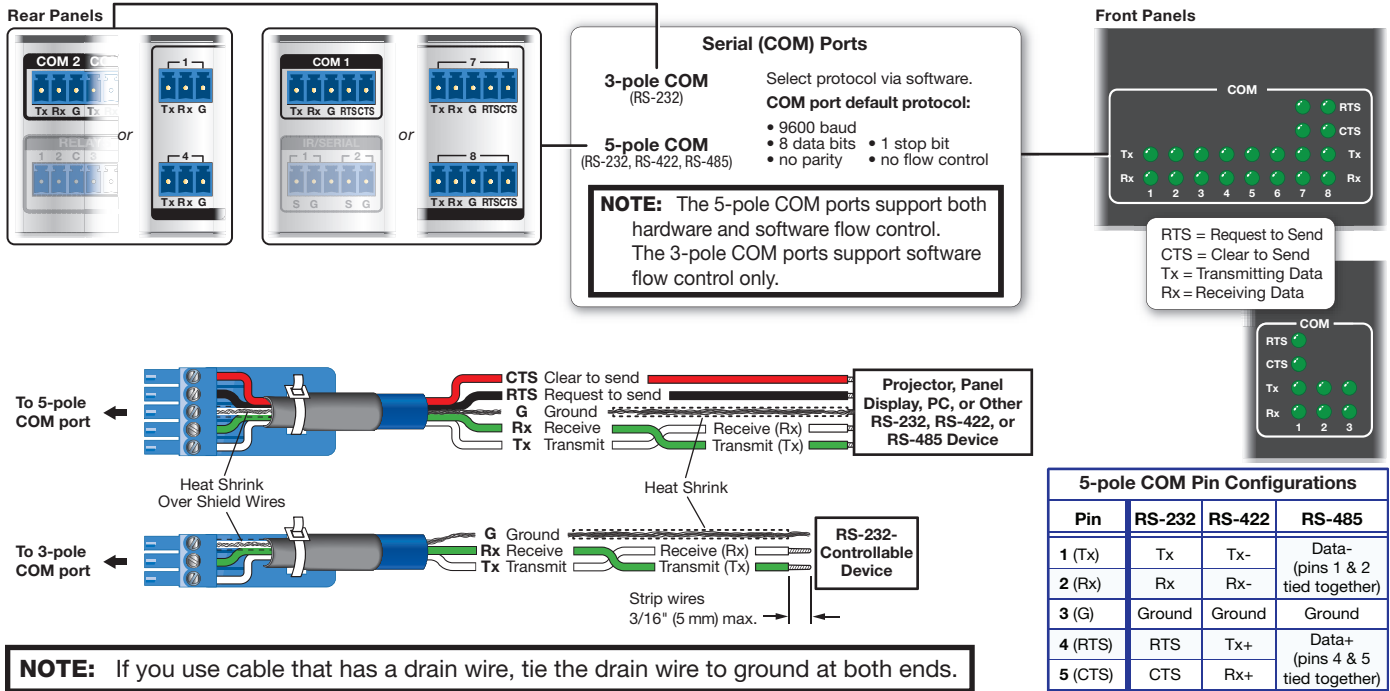

Control, Bidirectional – LAN and AV LAN (Ethernet)

Default port IP addresses and recommended connections vary depending on whether or not the IPCP model includes AV LAN ports.

xi models – LAN ports

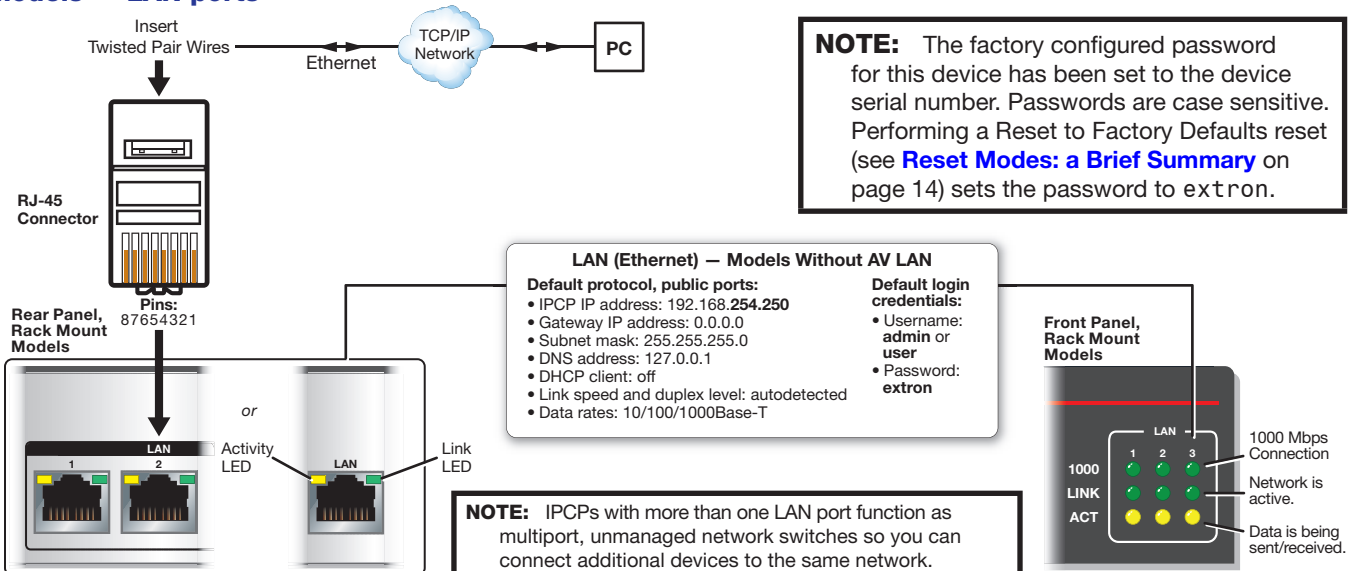

IPCP Pro Q xi and xi Series • Setup Guide (Continued)

Q xi models – LAN ports

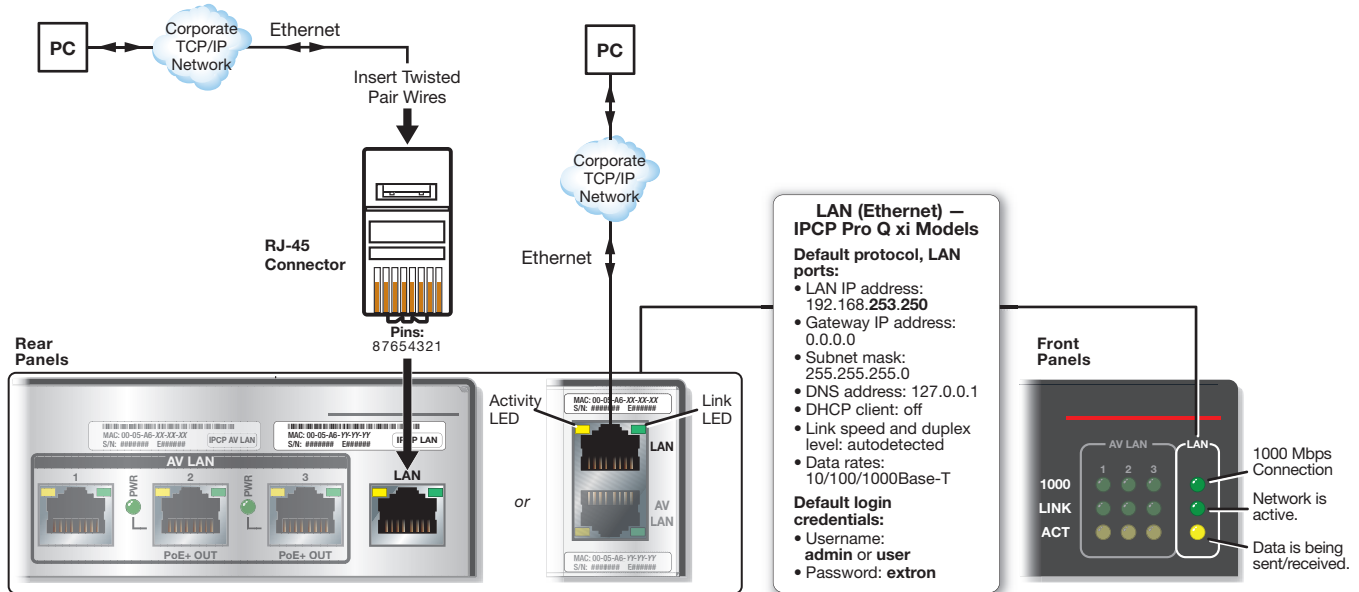

NOTES:

- IPCPs with more than one LAN or AV LAN port function as multiport, unmanaged network switches so you can connect additional devices to the same network.
- The factory configured passwords for this device have been set to the device serial number. Passwords are case sensitive. Performing a Reset to Factory Defaults reset (see [Reset Modes: a Brief Summary](#) on page 14) sets the passwords to extron.

Q xi models – AV LAN ports

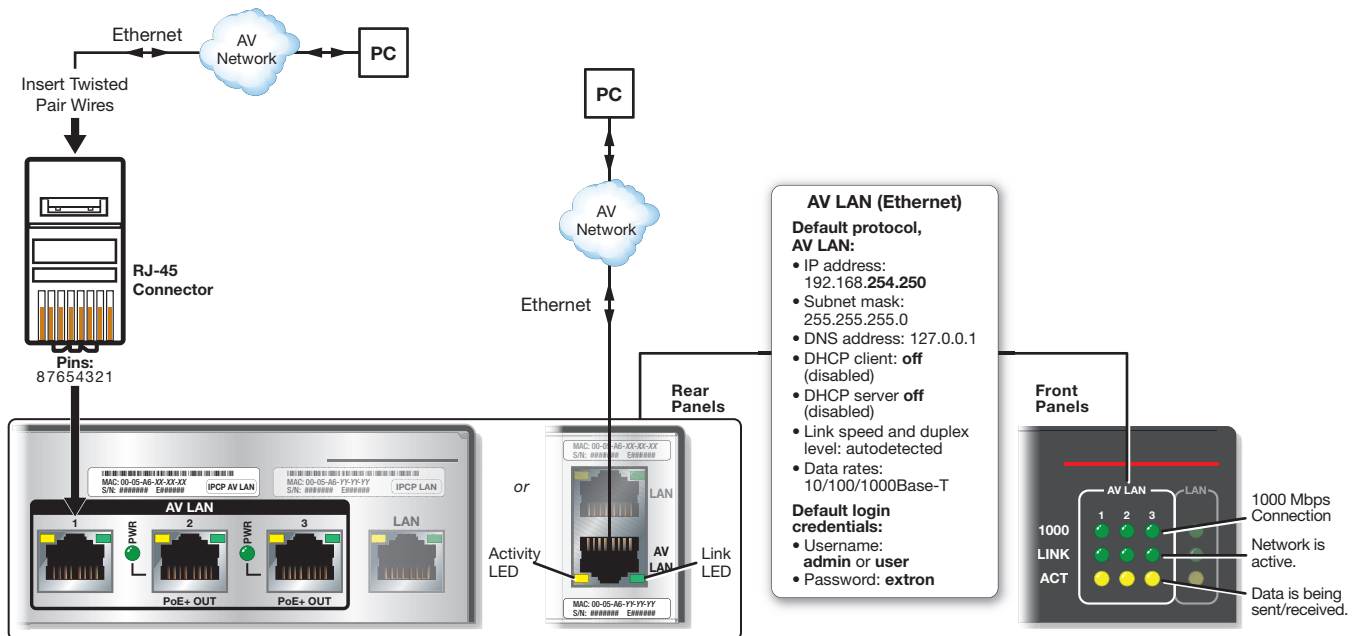

NOTES:

- IPCPs with more than one LAN or AV LAN port function as multiport, unmanaged network switches so you can connect additional devices to the same network.
- The factory configured passwords for this device have been set to the device serial number. Passwords are case sensitive. Performing a Reset to Factory Defaults reset (see [Reset Modes: a Brief Summary](#) on page 14) sets the passwords to extron.

AV LAN DHCP Server

The AV LAN DHCP Server is disabled by default. It can be enabled to dynamically assign IP addresses to DHCP clients on the AV LAN.

Default protocol, AV LAN when DHCP server is enabled:

- DHCP server IP address: 192.168.254.1
- Subnet mask: 255.255.255.0
- DNS address: 192.168.254.1
- DHCP dynamic address range for client devices: 192.168.254.100 - 192.168.254.149
- Maximum served addresses when DHCP server is enabled: 50
- DHCP client address lease time: 24 hours.

To use DHCP in the AV LAN:

1. Using Toolbelt, enable the DHCP server for the AV LAN within the control processor (see the software or programming help file for details).
2. Enable DHCP on each client AV device (see the user guide for each product).
3. Connect client AV devices to the AV LAN.

PoE+ output: The IPCP Pro 360Q xi offers Power over Ethernet+ (PoE+) output on AV LAN ports 2 and 3. These RJ-45 connectors, labeled “PoE+ Out,” can output a maximum of 30 watts per port. The corresponding Power LED lights when the port provides power. PoE+ ports can be monitored for status and power consumption, and power output can be scheduled. For details, see the *IPCP Pro Q xi and xi Series User Guide* and the *Global Configurator Help File*.

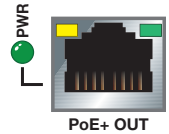

ATTENTION:

- Power over Ethernet (PoE) is intended for indoor use only. It is to be connected only to networks or circuits that are not routed to the outside plant or building.
- L'alimentation via Ethernet (PoE) est destinée à une utilisation en intérieur uniquement. Elle doit être connectée seulement à des réseaux ou des circuits qui ne sont pas routés au réseau ou au bâtiment extérieur.

All models (with or without AV LAN)

MAC address: Each network interface of the control processor is assigned a unique user hardware ID number (MAC address) (for example, 00-05-A6-05-1C-A0). You may need this address during control processor configuration. A label that indicates the MAC address is located on the rear or side panel of the unit.



Control, Unidirectional – IR/Serial

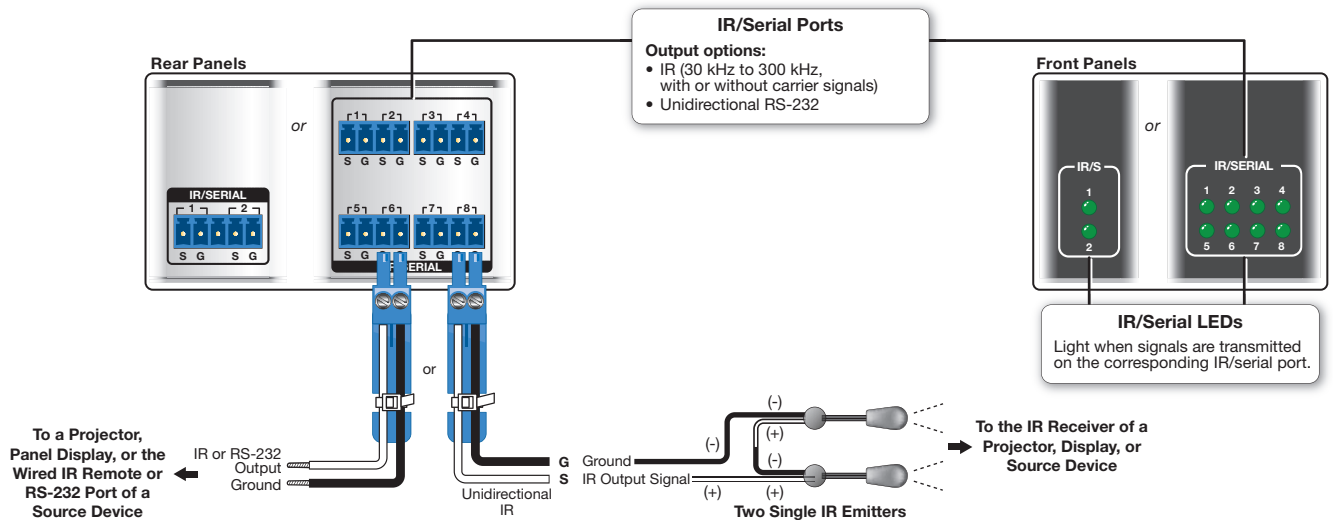

Control, Unidirectional – Relays

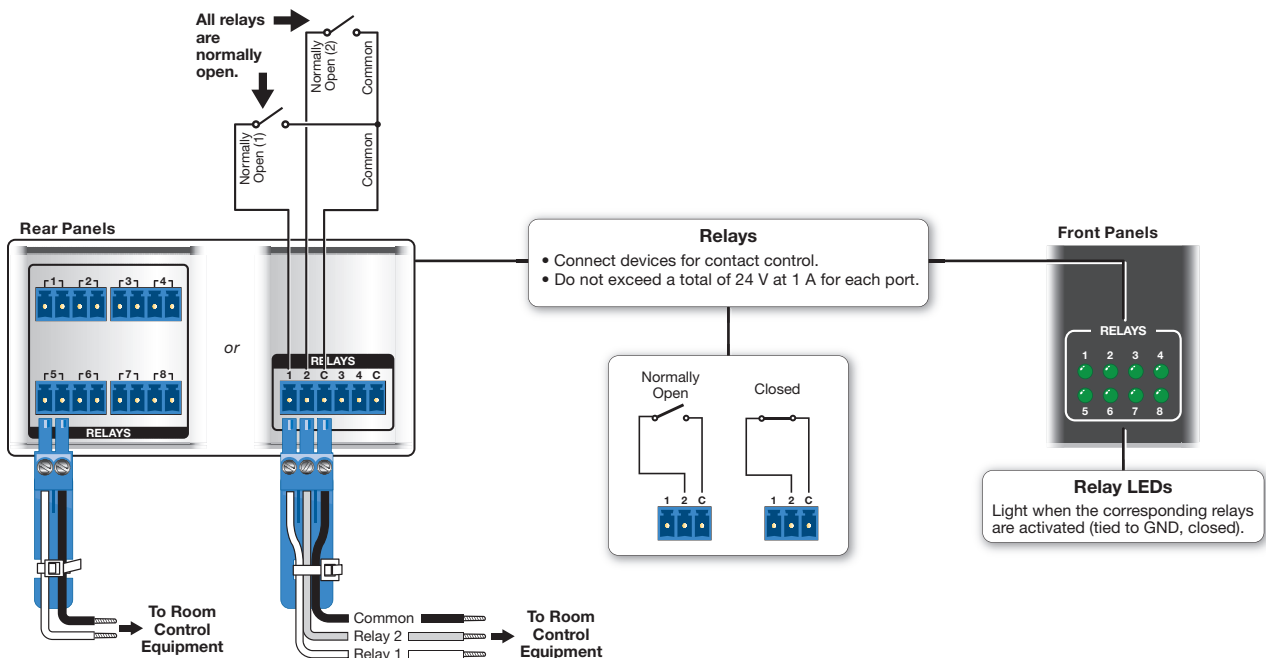

IPCP Pro Q xi and xi Series • Setup Guide (Continued)

Control, Unidirectional – Flex I/O or Digital I/O

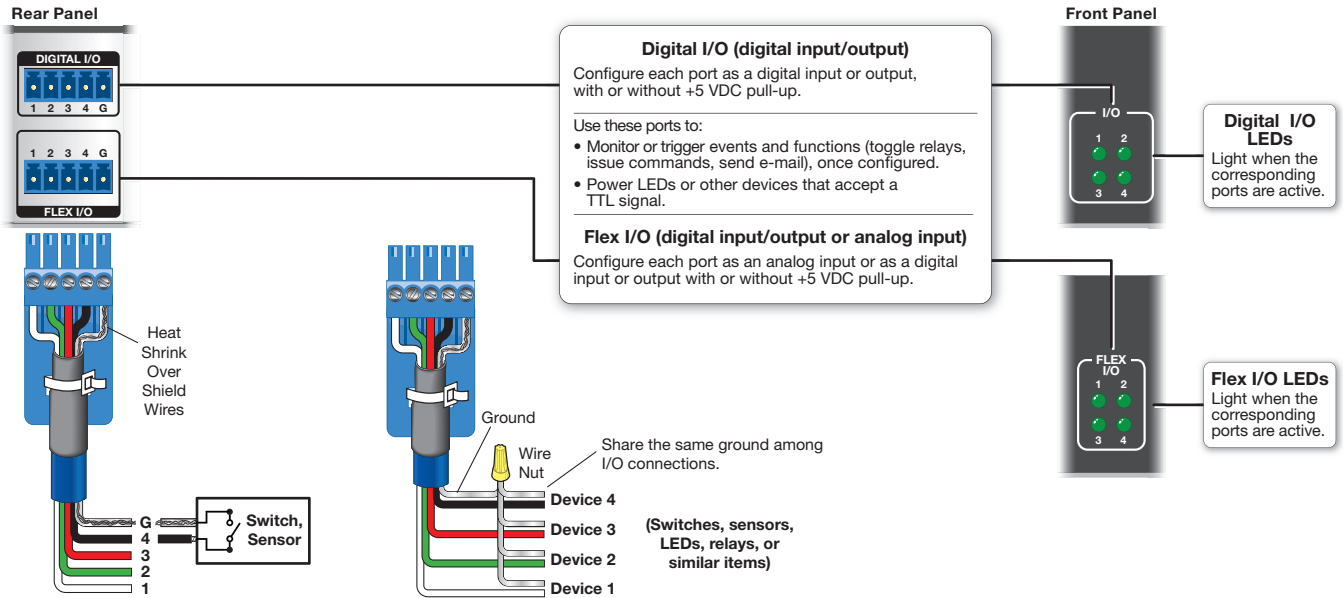

Control – eBUS

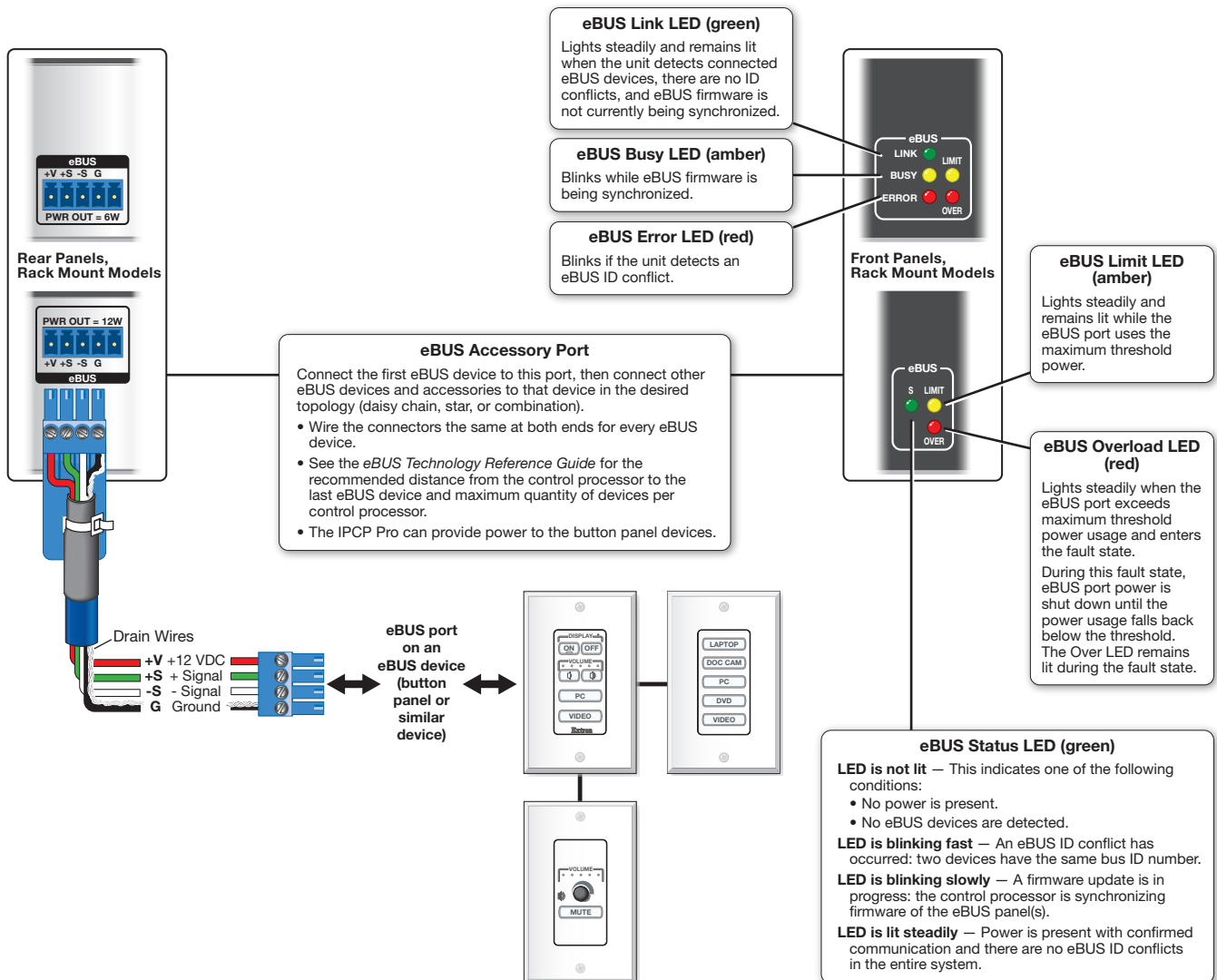

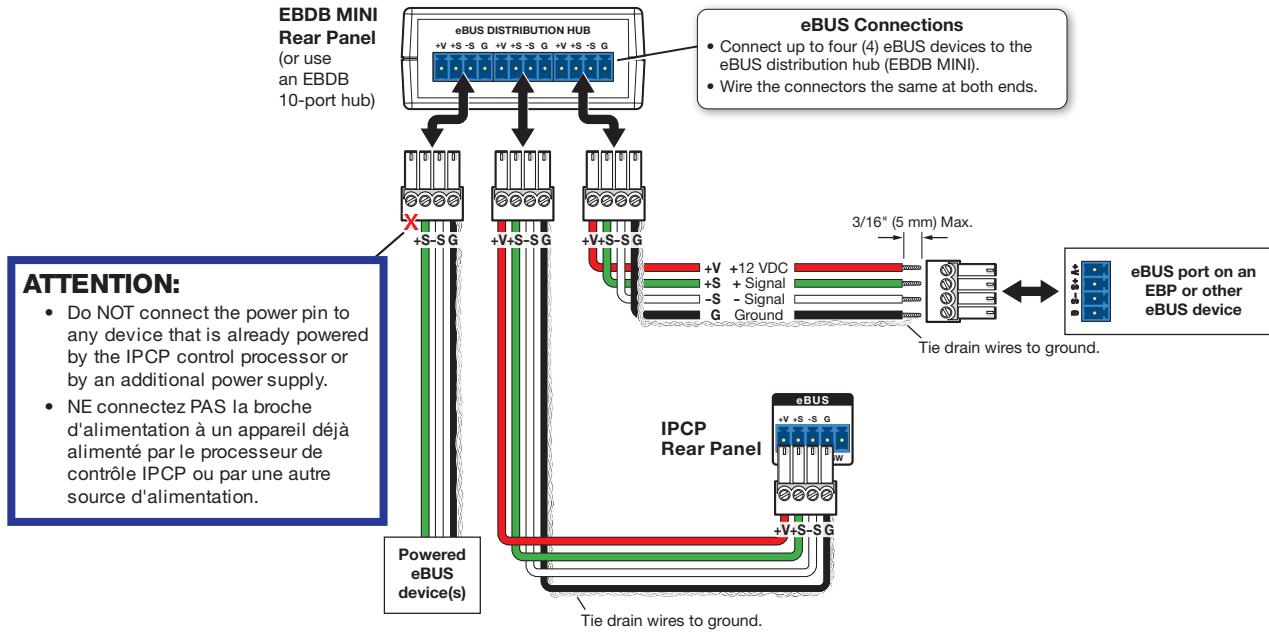

Control – Volume

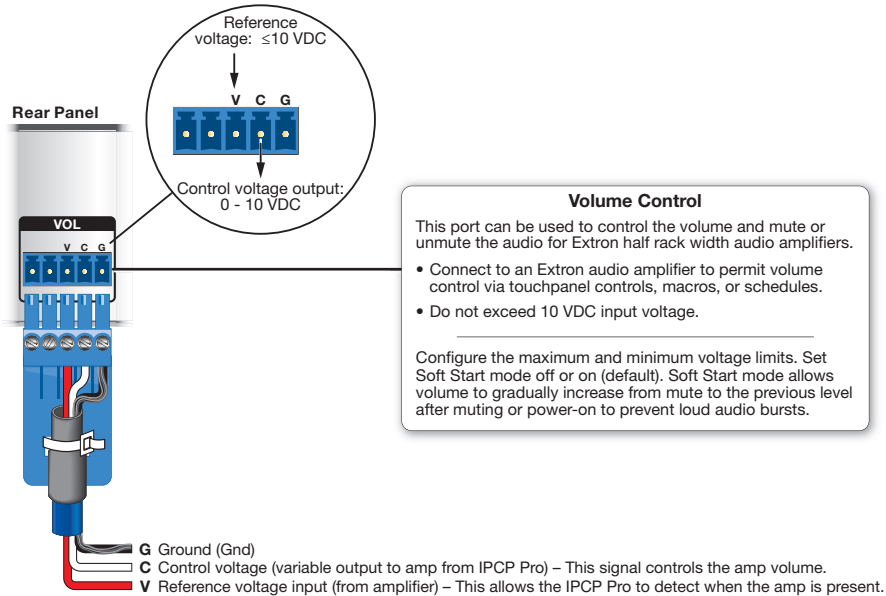

Example:

Connecting to Extron Amplifiers

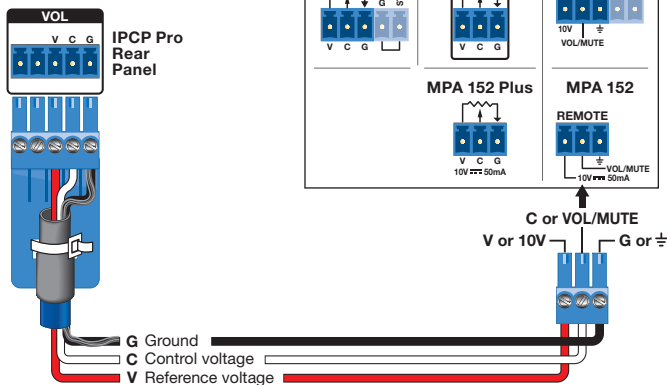

NOTE: When audio mute is active, the control processor sets output voltage to 0 VDC, even if the voltage range (minimum and maximum voltage limits) has been set to levels above zero, such as 2 V to 8 V.

IPCP Pro Q xi and xi Series • Setup Guide (Continued)

Reset Modes: a Brief Summary

NOTE: The IPCP Pro xi reset button is separate from the FOX3 matrix reset button on the IPCP Pro FOX3 Matrix Q xi (see [figure 5](#) on page 7). Use the FOX3 matrix reset button to execute matrix switcher-specific reset functions, which are detailed in the “Operations” section of the *FOX3 Matrix Series User Guide* (available at www.extron.com).

The IP Link Pro control processors offer the following reset modes:

- **Run Factory Boot Code:** Press and hold the front panel **Reset** button while applying power to the unit. Keep holding the button down until the Power LED blinks twice, or for 6 seconds, then release the button. The LED blinks slowly during bootup. The control processor runs the factory boot code (rather than full firmware). Upload new firmware to the unit (see “Updating the Firmware” in the user guide for details).
 - Use this mode to temporarily boot up the unit running only the factory boot code, then install the desired firmware.
 - Use this in the event that a firmware update has failed or if incompatibility issues arise with user-loaded firmware.

NOTES:

- **Do not** continue to operate the control processor using only the factory boot code. The unit requires a full firmware package in order to be fully operational. If you want to use the firmware version with which the unit shipped, you must upload that version again (see the *Global Configurator Help File* or *Toolbelt Help File* for firmware upload instructions).
- To return the unit to the firmware version that was running prior to the reset, cycle power to the unit instead of installing new firmware.

- **Project Recovery:** See the *IPCP Pro Q xi and xi Series User Guide* for instructions. Use this mode in conjunction with GC software to recover the project in the event of a lost user name and password.
- **Run/Stop Program:** Hold down the **Reset** button for about 3 seconds, until the Power LED blinks once. Release and press the **Reset** button momentarily (for <1 second) within 1 second. (Nothing happens if the momentary press does not occur within 1 second.) The LED blinks 2 times if scripts and systems are starting. The LED blinks 3 times if they are stopping. This mode allows you to restart any programs stopped by an IP settings reset.
- **Toggle DHCP Client:** Press the **Reset** button five times (consecutively). Release the button. Do not press the button within 3 seconds following the fifth press. Use this mode to enable or disable the DHCP client for the LAN port.
 - The Reset LED blinks 6 times if the DHCP client is enabled.
 - The Reset LED blinks 3 times if the DHCP client is disabled.

NOTES:

- By default DHCP is off for the LAN port and the unit uses a static IP address.
- If DHCP has been enabled, when you disable DHCP, the unit reverts to using the previously-set static IP address.

- **Reset All IP Settings:** Press and hold the front panel **Reset** button until the Power LED blinks once at 3 seconds and twice at 6 seconds. Release and momentarily press the **Reset** button within 1 second. The LED blinks 3 times in quick succession upon successful reset.

Use this mode to reset all network settings to factory default values without affecting user-loaded files. This reset mode also stops any running programs and disables 802.1X authentication. Lastly, this mode resets the settings for both LAN and AV LAN ports, including turning DHCP off.
- **Reset to Factory Defaults:** Press and hold the front panel **Reset** button for 9 seconds until the Power LED blinks once at 3 seconds, twice at 6 seconds, and thrice at 9 seconds. Release and momentarily press the **Reset** button within 1 second. The Power LED blinks 4 times in quick succession upon successful reset.

Use this mode to return the control processor to factory default settings. This mode also deletes all user-loaded files and configurations (except LinkLicense files), and it clears messages in the event logs table. User-loaded digital certificates are deleted. The unit continues to run the user-loaded firmware.

For detailed information on each mode and its use, see the *IPCP Pro Q xi and xi Series User Guide* at www.extron.com.

Resources

Obtaining Control Drivers

Extron provides an extensive selection of device drivers available on the Extron website. If the system requires a control driver that is not already available, you have additional options:

- Request a new serial (RS-232) or Ethernet driver from Extron.
- Create your own custom IR device driver using IR Learner Pro software. Follow the directions in the *IR Learner Pro Help File* to create a driver by using the remote control for that device and the IR receiver port on the front panel of the IPCP.

Obtaining Instructions, Information, and Assistance

A checklist of basic setup steps is provided at the beginning of this guide. For additional information see the help files and the *IPCP Pro Q xi and xi Series User Guide*, available at www.extron.com.

If you have questions during installation and setup, call the [Extron S3 Sales & Technical Support Hotline](tel:18006339877) or the Extron S3 Control Systems Support Hotline (1.800.633.9877).

Locating Software, Firmware, and Driver Files on the Extron Website

There are three main ways to find software, firmware, and device drivers within www.extron.com:

- Via links from the web page for the specific product
- Via the [Download](#) page (Click on the **Download** tab at the top of any page within www.extron.com.)
- Via links from search results

NOTES:

- For some software you have the option to click the **Download Now** button to begin downloading the software file. For other software there is a link for contacting an Extron support representative who can provide you access to the latest version. To obtain Extron control product software, you must have an Extron Insider account. Extron provides training to our customers on how to use the software. Access to the full features of Global Configurator Professional is available to those who successfully complete Extron Control Professional Certification.
- **IP Link Pro Series RS-232 and Ethernet drivers are required.** You must use serial and Ethernet drivers developed specifically for the IP Link Pro platform. With the exception of IR device drivers, drivers used for the previous generation IP Link (non-Pro) control processors are not compatible.

Overall Configuration Procedure for the Control Processor

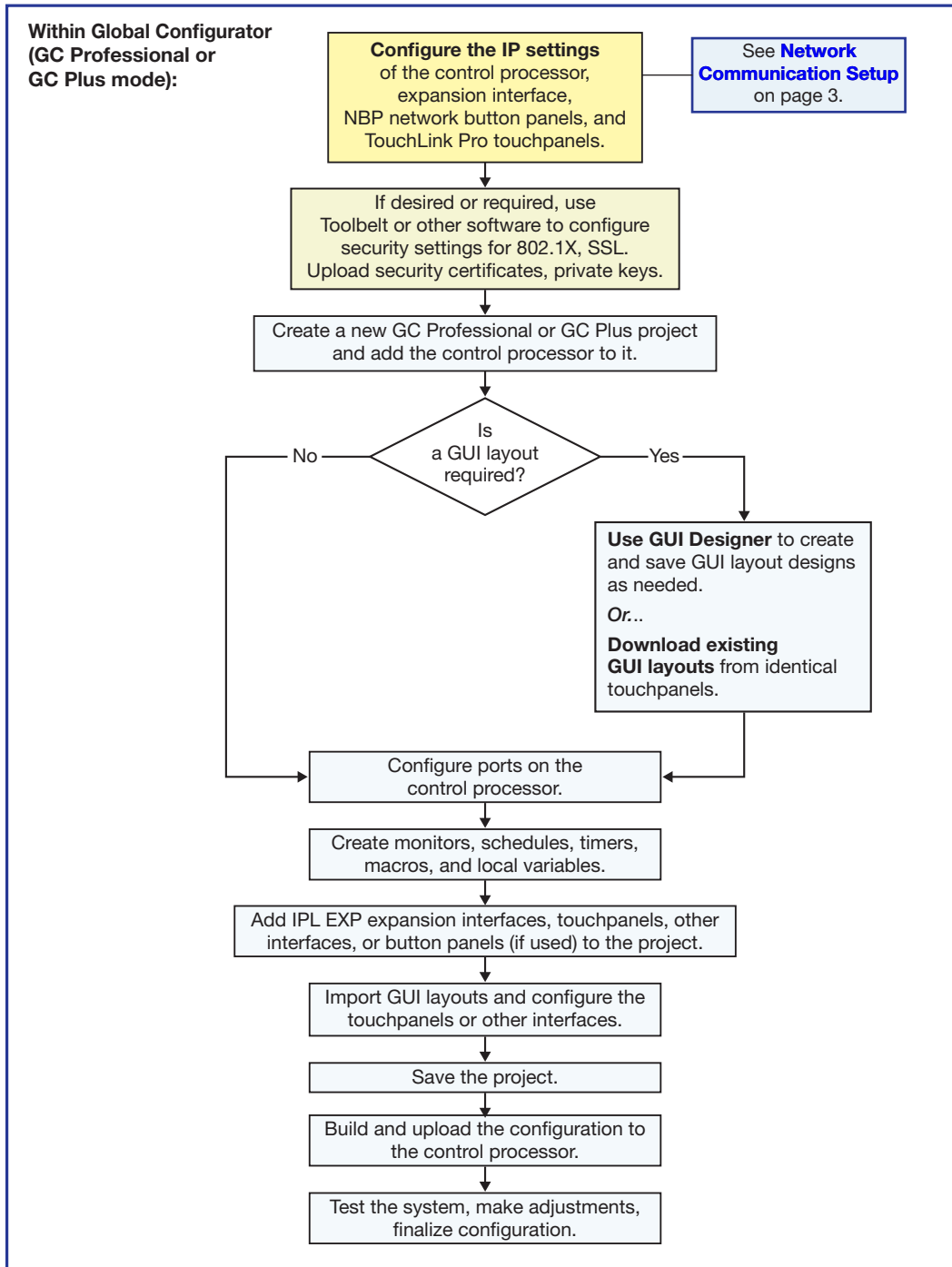

Figure 6. Overall Configuration Steps

For information on safety guidelines, regulatory compliances, EMI/EMF compatibility, accessibility, and related topics, see the **Extron Safety and Regulatory Compliance Guide** on the Extron website.