

EBDB Mini • Setup Guide

The Extron EBDB Mini is an eBUS® power and signal distribution hub for use with eBUS-enabled IP Link® Pro control processors. It includes four eBUS ports, connected in parallel, which allows each port to act as an input or an output for communication between IPCP Pro control processors and other eBUS devices. A front panel LED indicates when power is present on one or more of the ports.

The EBDB does not need to be set up. Other components of an eBUS-enabled system (an IPCP Pro control processor and eBUS peripheral products such as EBPs [eBUS button panels]) must be configured using Extron Global Configurator (GC) software (in GC Professional or GC Plus mode), which is available at www.extron.com.

Features

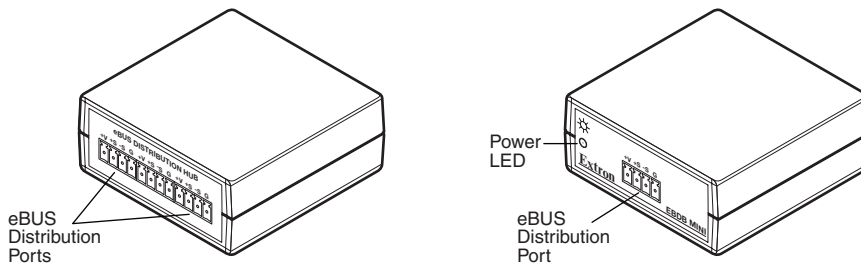

Figure 1. EBDB Mini Rear and Front Panel Features

Cabling: eBUS Connections

Attach cables using the following diagrams as a guide. Extron STP20-2/1000 or STP20-2P/1000 cable is recommended for eBUS connections.

ATTENTION: Installation and service must be performed by authorized personnel only.

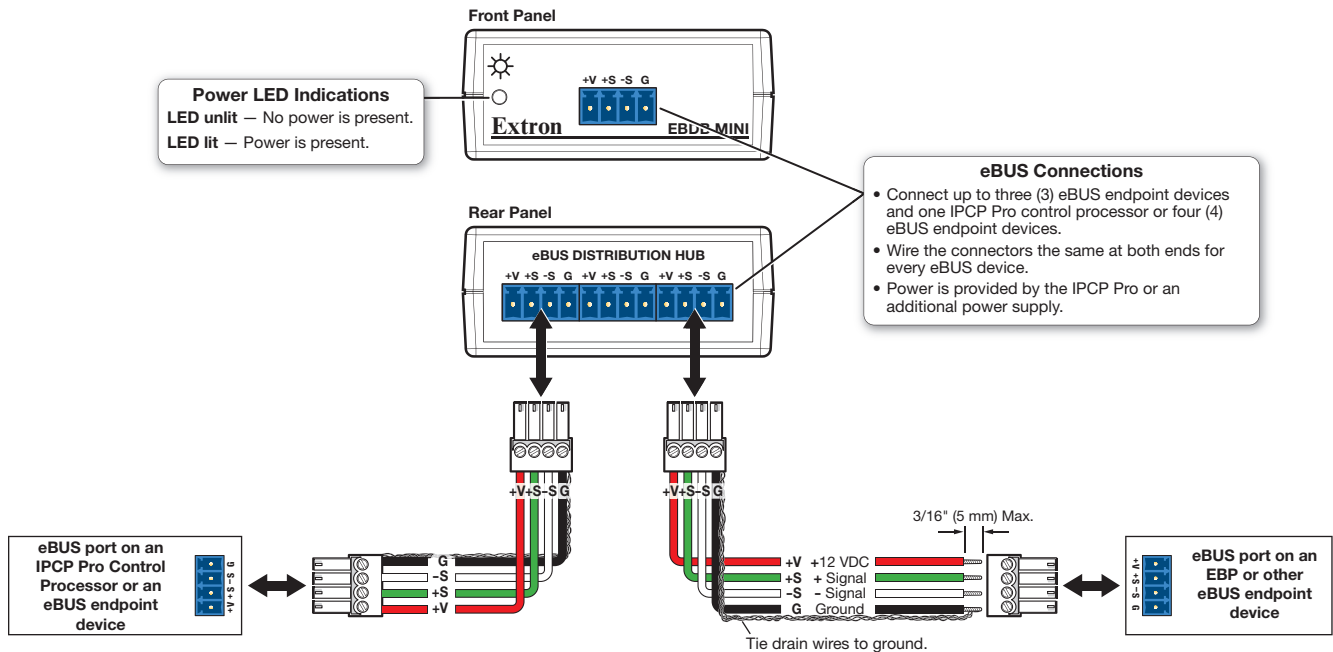

Figure 2. Basic eBUS Wiring and Indications

EBDB Mini • Setup Guide (Continued)

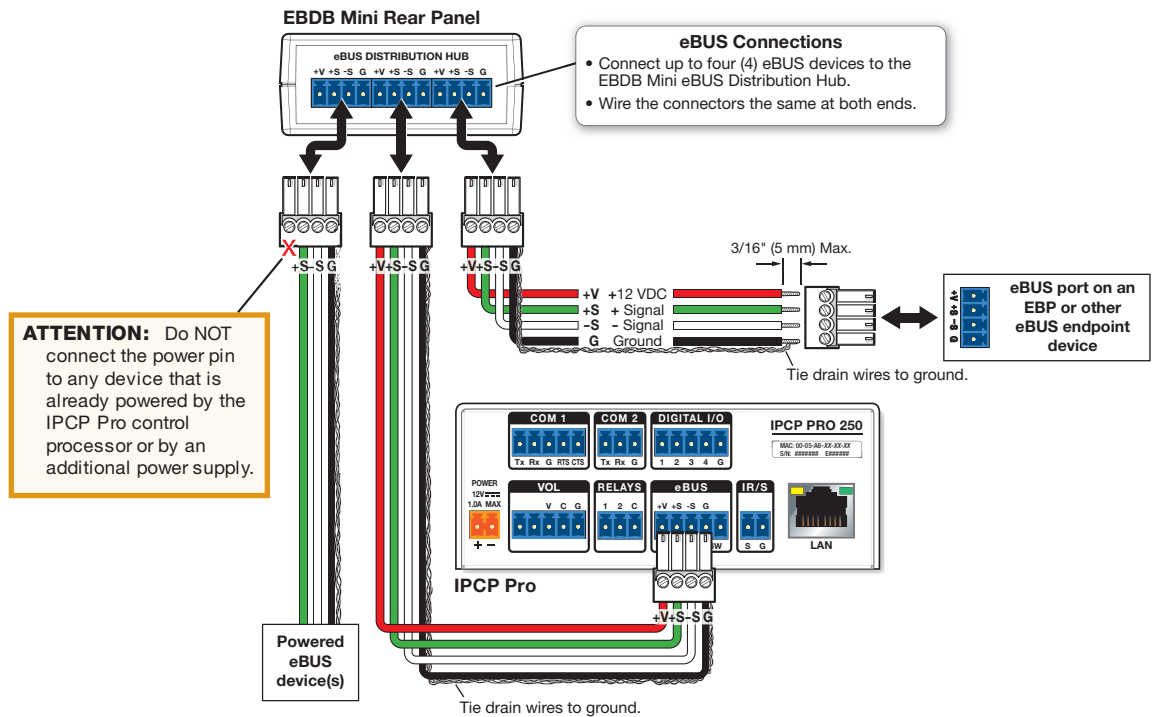

Figure 3. eBUS Wiring for a System with Two Power Sources

Installation

1. Mount the EBDB Mini as desired and mount the IPCP Pro to a rack or furniture (see the *IPCPC Pro User Guide* at www.extron.com).
2. Connect the EBDB Mini and any eBUS endpoint devices to each other in a daisy-chain or a star arrangement (see the *eBUS Technology Reference Guide* for information about daisy chain and star topologies). Wire both ends of each cable the same (pin 1 to pin 1, pin 2 to pin 2, and so forth).
3. Connect the IPCP Pro to the EBDB Mini, making sure that both ends of the cable are wired the same.

NOTE: See the attention information in figure 3 so you do not connect the power pins (labeled V+) on the EBDB Mini to two powered devices. Power should be supplied to the EBDB Mini by only one source.

4. Connect power to the devices, connect the IPCP Pro to a network, and set up the IPCP Pro and its connected eBUS endpoint devices.

Additional Instructions, Information, and Assistance

- Instructions on configuration are available in the user and setup guides for the IPCP Pro control processor and in the *Global Configurator Help* file. The *Global Configurator Help* file includes an introduction to the software and how to start a GC project, as well as instructions on configuration.
- See the *eBUS Technology Reference Guide* for details about eBUS addresses, topologies, and firmware updates.
- Software, help files, and guides are all available at www.extron.com.
- If you have questions during installation and setup, call the [Extron S3 Sales & Technical Support Hotline](tel:+18006339877) or the Extron S3 Control Systems Support Hotline (1.800.633.9877).

Mounting

You can set an EBDB Mini on a tabletop or attach it to an equipment rack or furniture by using adhesive-backed hook-and-loop tape.

68-3049-50
Rev. A
10 16

Extron Headquarters +1.800.633.9876 (Inside USA/Canada Only)	Extron Europe +800.3987.6673 (Inside Europe Only)	Extron Asia +65.6383.4400 +65.6383.4664 FAX	Extron Japan +81.3.3511.7655 +81.3.3511.7656 FAX	Extron China +86.21.3760.1568 +86.21.3760.1566 FAX	Extron Middle East +971.4.299.1800 +971.4.299.1880 FAX	Extron Australia +61.8.8351.2188 +61.8.8351.2511 FAX	Extron India 1800.3070.3777 (Inside India Only) +91.80.3055.3777 +91.80.3055.3737 FAX
Extron USA - West +1.714.491.1500 +1.714.491.1517 FAX	Extron USA - East +1.919.850.1000 +1.919.850.1001 FAX						