

## UTM 100 and UTM 150 • Installation Guide

The Extron UTM 100 and UTM 150 under-table mounts accommodate 1U and 2U full rack width products. Follow the steps below to assemble and install the UTM 100 and UTM 150 under a desk or table.

### Installing the UTM 100 (Primary Mount) on the Product

Follow the steps below to attach the UTM 100 mounts to the primary product. Attach a UTM on each rack ear (left and right).

**NOTE:** Rack mounts or rack shelf kits may be purchased separately for products that do not have rack ears (see [www.extron.com](http://www.extron.com) for models and part numbers).

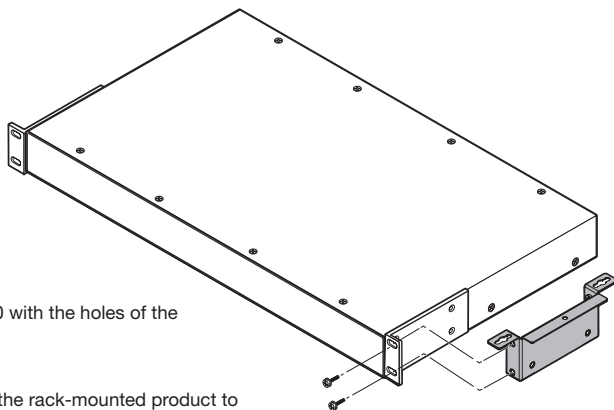

- 1 Align the holes of the UTM 100 with the holes of the rack ear, as shown at right.
- 2 Use the screws provided with the rack-mounted product to attach the UTM 100.

### Mounting the UTM 100 Assembly

- 3 Hold the UTM 100 assembly under the desk or table at the mounting location, and mark the locations of the four mounting holes.
- 4 Drill a 3/32 inch (2.38 mm) diameter pilot hole at each of the four marked locations.

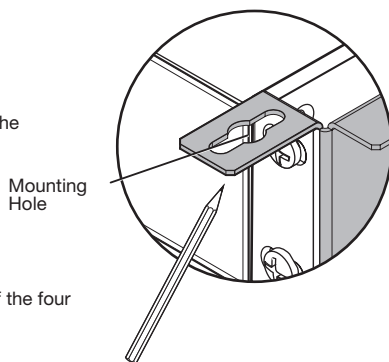

**ATTENTION:** Do not drill through the table or furniture. If the table is too thin or of a different material for the supplied screws, use an appropriate type and length.

**ATTENTION :** Ne percez pas à travers la table ou le meuble. Si la table est trop fine ou faite dans un matériau différent de celui pour lequel les vis fournies sont prévues, utilisez un type de matériau et une longueur appropriés.

# UTM 100 and UTM 150 • Installation Guide (Continued)

- 5** Insert a #8 x 1/2 inch mounting screw (provided) into each of the four holes. Tighten each screw until it protrudes 1/4 inch from the bottom of the table.

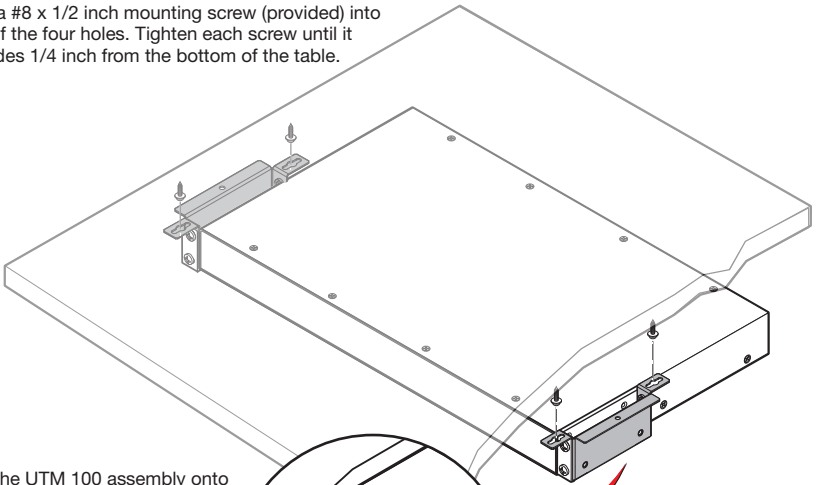

- 6** Hook the UTM 100 assembly onto the screws, as shown at right.

Slide the UTM assembly forward or backward into either slot.

Tighten the screws to secure the UTM assembly.

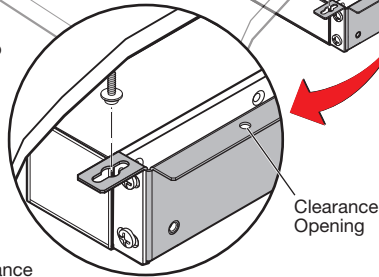

- 7** Drill a pilot hole through the clearance opening on the UTM 100. Insert and tighten a mounting screw (provided).

**NOTE:** If necessary for easier access, mark the location of the clearance opening, then remove the UTM system to drill the hole.

## Mounting the UTM 150

- 8** Use the provided #10-32 Phillips head screws to add one or more UTM 150 brackets to the UTM system (see image at right).

- 9** Mount products on the UTM 150 brackets, as shown in steps 1 and 2 on the previous page.

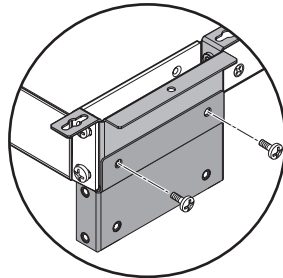

68-2661-01  
Rev. A  
08 14

Extron USA Headquarters  
+1.800.633.9876 (Inside USA/Canada Only)

Extron USA - West: +1.714.491.1500  
Extron USA - East: +1.919.850.1000

FAX: +1.714.491.1517  
FAX: +1.919.850.1001